



OG 570-3

OG 550-3

OG 530-3

OG 575-8°

OG 570-12.5°

OG 570-8.5°

OG 565

OG 550-12.5°

OG 550-7.5°

OG 530

OG 510

- **ORGANO DI PRESA A GINOCCHIERA A DUE LEVE**
- **Two-lever toggle gripper**
- **Zwei-finger Kniehebelgreifer**
- **Pince de préhension à genouillère, à deux leviers**

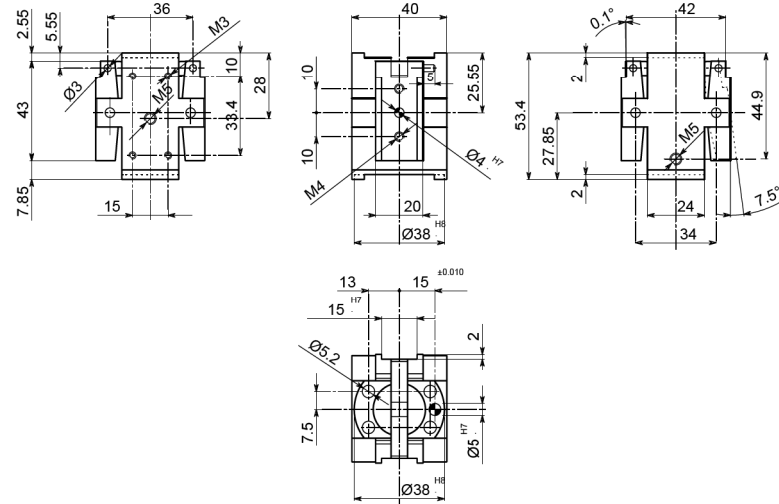

• Le dimensioni sono indicative e suscettibili di variazioni per migliorie tecniche. Ci riserviamo di apportare modifiche senza preavviso • All dimensions are indicative and subject to variation for technical upgrading. We reserve the right to make alterations without prior notification • Die Maßangaben sind indikativ und können sich bei technischen Verbesserungen ändern. Wir behalten uns vor, ohne vorherige Benachrichtigung Änderungen vorzunehmen • Les dimensions sont fournies à titre indicatif, elles peuvent subir des variations pour cause d'améliorations techniques. Nous nous réservons le droit d'apporter des modifications sans préavis.

• **SCHEMA DI FUNZIONAMENTO • OPERATIONAL DIAGRAM**
• **BETRIEBSSCHEMA • SCHEMA DE FONCTIONNEMENT**

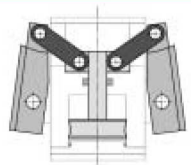

Aperto
Open
Geöffnet
Ouvert

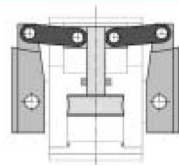

Chiuso
Closed
Geschlossen
Formé



tecnomors spa. - Via Roma 141/143 - 28017 San Maurizio d'Opaglio (NO) - Italy
tel.: 0322 96142 - fax.: 0322 967453 - e mail: info@tecnomors.it



OG 570-3

OG 550-3

OG 530-3

OG 575-8°

OG 570-12.5°

OG 570-8.5°

OG 565

OG 550-12.5°

OG 550-7.5°

OG 530

OG 510

- **ORGANO DI PRESA A GINOCCHIERA A DUE LEVE**
- **Two-lever toggle gripper**
- **Zwei-finger Kniehebelgreifer**
- **Pince de préhension à genouillère, à deux leviers**

DIAGRAMMA FORZA DI CHIUSURA
CLAMPING FORCE DIAGRAM • DIAGRAM SCHLIEßKRAFT
DIAGRAMME DE LA FORCE DE FERMETURE

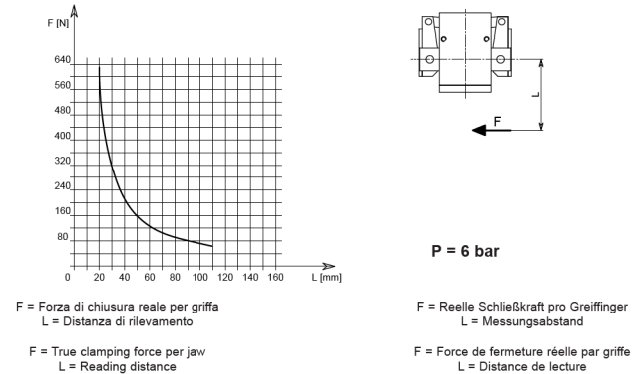

Valori rilevati nel punto morto di ginocchiera (0°) • Values read in toggle position (0°)
• Werte in Kniehebelstellung (0°) • Valeurs relevées en position de genouillère (0°)

DATI TECNICI

Corsa per griffa	7.5°
Corsa pistone	8.5 mm
Volume aria per doppia corsa	5 cm ³
Spinta sul pistone in chiusura a 6 bar	188 N
Coppia teorica di chiusura per griffa a 6 bar	18 Nm
Coppia reale di chiusura per griffa a 6 bar	13 Nm
Pressione di esercizio	2-8 bar
Ripetibilità	±0.05 mm
Peso	0.28 Kg
Temperatura di esercizio	5-60 °C
Codice articolo	OP630GHB

TECHNISCHE DATEN

Hub pro Greiffinger	7.5°
Kolbenhub	8.5 mm
Luftvolumen pro Doppelhub	5 cm ³
Kolbendruck 6 bar	188 N
Theoretisches Schließdrehmoment pro Greiffinger 6 bar	18 Nm
Reelles Schließdrehmoment pro Greiffinger 6 bar	13 Nm
Betriebsdruck	2-8 bar
Wiederholbarkeit	±0.05 mm
Gewicht	0.28 Kg
Betriebstemperatur	5-60 °C
Artikelcode	OP630GHB

SPECIFICATIONS

Stroke per jaw	7.5°
Piston stroke	8.5 mm
Dual stroke air volume	5 cm ³
Force on piston at 6 bar	188 N
Theoretical clamping couple per jaw at 6 bar	18 Nm
Actual clamping couple per jaw at 6 bar	13 Nm
Working pressure	2-8 bar
Reproducibility	±0.05 mm
Weight	0.28 Kg
Working temperature	5-60 °C
Article code	OP630GHB

DONNÉES TECHNIQUES

Course par griffe	7.5°
Course piston	8.5 mm
Volume d'air pour course double	5 cm ³
Poussée sur le piston à 6 bar	188 N
Couple théorique en fermeture par griffe à 6 bar	18 Nm
Couple réel en fermeture par griffe à 6 bar	13 Nm
Pression d'exercice	2-8 bar
Répétibilité	±0.05 mm
Poids	0.28 Kg
Température d'exercice	5-60 °C
Code article	OP630GHB



tecnomors spa. - Via Roma 141/143 - 28017 San Maurizio d'Opaglio (NO) - Italy
tel.: 0322 96142 - fax.: 0322 967453 - e mail: info@tecnomors.it