



organi di presa - grippers - greifer - organes de préhension

**engineering manual
& design guide**



- **ORGANI DI PRESA A CORSA PARALLELA A DUE GRIFFE.**
- **Two jaw parallel stroke grippers**
- **Zwei-finger Parallelgreifer**
- **Organes de préhension à course parallèle à deux griffes.**

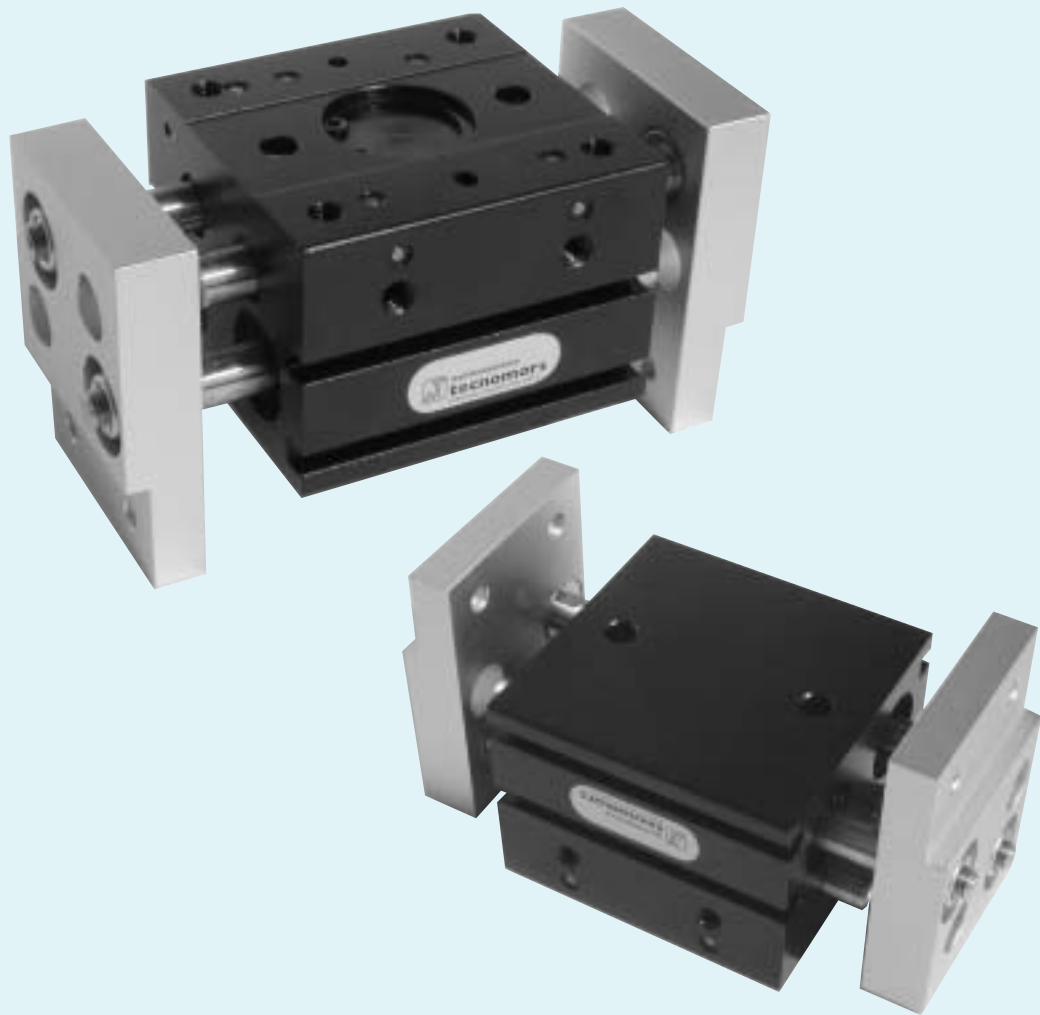

VRG >>



- **ORGANI DI PRESA A CORSA PARALLELA A DUE GRIFFE.**
- **Two jaw parallel stroke grippers**
- **Zwei-finger Parallelgreifer**
- **Organes de préhension à course parallèle à deux griffes.**

I Le pinze di questa gamma sono progettate per il bloccaggio esterno o interno del particolare da movimentare, e sono studiate appositamente per offrire i seguenti vantaggi:

- compattezza di dimensioni con un'ampia gamma di di corse disponibili;
- cinque grandezze di pinza con tre versioni di corsa per ogni modello;
- permettono la manipolazione di carichi di grandi dimensioni e soprattutto di dimensioni variabili;
- meccanismo a doppio pistone per ottenere il massimo della forza pur rimanendo in ingombri contenuti;
- movimento delle griffe sincronizzato con sistema pignone-cremagliera;
- le aste di guida sono supportate da bussole in materiale autolubrificante e sono equipaggiate con guarnizioni di protezione dallo sporco;
- il corpo è provvisto di scanalature per l'introduzione di sensori di prossimità magnetici, senza aggiungere ulteriori ingombri esterni.

GB This range of grippers is realized for the external and internal clamping of the part and they offer the following advantages:

- compact design and wide range of strokes available;
- five dimensions with three versions of stroke for each model;
- they allow the gripping of high weights and variable sizes;
- double piston construction materializes a high gripping force with reduced dimensions;
- finger motion synchronization by a rack- and pinion mechanism;
- shaft equipped with self lubricated bearings and with dirt protected seals;
- grooves in the body allow the proximity switches introduction.

D Diese Greiferserie wurde zum Außen- und Innengreifen von Werkstücken entwickelt. Sie weisen folgende Vorteile auf:

- kompakte Ausführung mit einer Vielzahl von Hubmöglichkeiten;
- fünf Baugrößen mit je 3 Hubvarianten für jedes Modell;
- Sie ermöglichen das Greifen von großen Gewichten und verschiedenen Baugrößen;
- Doppelkolben-Konstruktion ermöglicht große Greifkräfte bei kleiner Bauform;
- Synchronisierung der Greiferbackenbewegung durch Ritzel-Zahnstangen Mechanismus;
- Spindel ist mit ausgerüstet selbstschmierenden Lagern und Schmutzabstreifern;
- Nuten im Gehäuse zum Einbau der Näherungsschalter;

F Cette gamme de pinces a été conçue pour un serrage interne ou externe et offre également les avantages suivants:

- pince compact et nombreuses courses disponibles;
- cinq tailles en trois courses disponibles par version;
- grande force constante permettant de déplacer des charges élevées de différentes dimensions;
- fonctionnement avec un double piston entraînant de fortes puissances dans un encombrement réduit;
- la synchronisation des mors s'effectue par un système de pignon-crémaillère;
- le guidage est réalisé par des douilles auto-lubrifiées équipées de joints de protection;
- le corps est muni de rainures permettant l'installation de capteurs de proximité;

• Schema costruttivo VRG • VRG Construction diagram.
• Konstruktionsschema VRG • Schéma de construction VRG

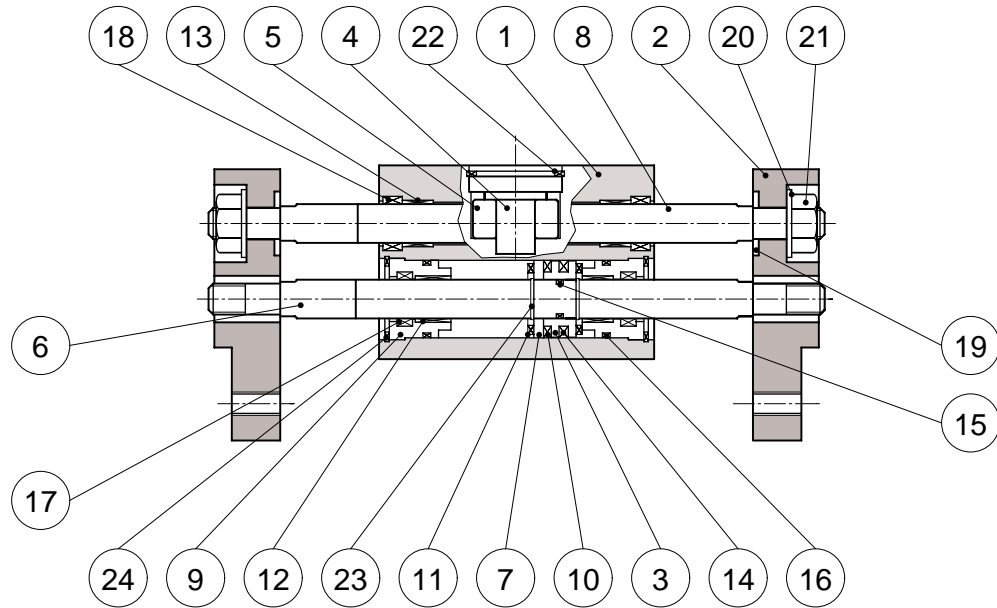

Nr.	Descrizione	Materiale	Note	No.	Beschreibung	Material	Anmerkungen
1	Corpo	Lega di alluminio	Ossidazione anodica	1	Körper	Aluminiumlegierung	Anodische oxydation
2	Griffa	Lega di alluminio	Ossidazione anodica	2	Backe	Aluminiumlegierung	Anodische oxydation
3	Pistone A	Ottone	-	3	Kolben A	Messing	-
4	Albero pignone	Acciaio	-	4	Ritzelstange	Stahl	-
5	Pignone	Acciaio	-	5	Ritzel	Stahl	-
6	Asta pistone	Acciaio inox	-	6	Führungskolbenstange	Rostfreier stahl	-
7	Pistone B	Ottone	-	7	Kolben B	Messing	-
8	Abero con cremagliera	Acciaio inox	-	8	Zahnstange	Rostfreier stahl	-
9	Fondello	Lega di alluminio	Ossidazione anodica	9	Boden	Aluminiumlegierung	Anodische oxydation
10	Magnete	Plastoferrite	-	10	Magnet	Plastoferrit	-
11	Paracolpi	NBR	cod. VRG per ricambio	11	Puffer	NBR	Code VRG für Ersatzteil
12	Bussola di guida	Bronzo	cod. VRG per ricambio	12	Führung	Bronze	Code VRG für Ersatzteil
13	Bussola di guida	Bronzo	cod. VRG per ricambio	13	Führung	Bronze	Code VRG für Ersatzteil
14	Raschiatore pistone	NBR	cod. VRG per ricambio	14	Schraper Dichtung	NBR	Code VRG für Ersatzteil
15	Guarnizione pistone	NBR	cod. VRG per ricambio	15	Kolben Dichtung	NBR	Code VRG für Ersatzteil
16	Guarnizione	NBR	cod. VRG per ricambio	16	Dichtung	NBR	Code VRG für Ersatzteil
17	Raschiatore asta	NBR	cod. VRG per ricambio	17	Stange Dichtung	NBR	Code VRG für Ersatzteil
18	Raschiatore asta	NBR	cod. VRG per ricambio	18	Stange Dichtung	NBR	Code VRG für Ersatzteil
19	Rondella	Acciaio	cod. VRG per ricambio	19	Scheibe	Stahl	Code VRG für Ersatzteil
20	Rondella	Acciaio	cod. VRG per ricambio	20	Scheibe	Stahl	Code VRG für Ersatzteil
21	Dado	Acciaio	cod. VRG per ricambio	21	U mutter	Stahl	Code VRG für Ersatzteil
22	Anello seeger	Acciaio	cod. VRG per ricambio	22	Sperring	Stahl	Code VRG für Ersatzteil
23	Anello	Acciaio inox	cod. VRG per ricambio	23	Ring	Rostfreier stahl	Code VRG für Ersatzteil
24	Anello seeger	Acciaio	cod. VRG per ricambio	24	Sperring	Stahl	Code VRG für Ersatzteil

No.	Description	Material	Note	No.	Description	Matière	Note
1	Body	Aluminium alloy	Alumite treatment	01	Corps	Alliage d'aluminium	Oxydation anodique
2	Finger	Aluminium alloy	Alumite treatment	02	Griffes	Alliage d'aluminium	Oxydation anodique
3	Piston A	Brass	-	03	Piston A	Laiton	-
4	Pinion shaft	Steel	-	04	Arbre pignon	Acier	-
5	Pinion	Steel	-	05	Pignon	Acier	-
6	Piston rod	Stainless steel	-	06	Tige de piston	Acier inox	-
7	Piston B	Brass	-	07	Piston B	Laiton	-
8	Rack shaft	Stainless steel	-	08	Arbre à crémaillère	Acier inox	-
9	Rod cover	Aluminium alloy	Alumite treatment	09	Culot	Alliage d'aluminium	Oxydation anodique
10	Magnet	Rubber magnet	-	10	Magnét	Plastoferrite	-
11	Damper	NBR	VRG code for replacement	11	Pare-chocs	NBR	Code VRG pour rechange
12	Bearing	Bronze	VRG code for replacement	12	Douille	Bronze	Code VRG pour rechange
13	Bearing	Bronze	VRG code for replacement	13	Douille	Bronze	Code VRG pour rechange
14	Piston packing	NBR	VRG code for replacement	14	Joint piston	NBR	Code VRG pour rechange
15	Piston gasket	NBR	VRG code for replacement	15	Joint piston	NBR	Code VRG pour rechange
16	Gasket	NBR	VRG code for replacement	16	Joint	NBR	Code VRG pour rechange
17	Rod packing	NBR	VRG code for replacement	17	Joint tige	NBR	Code VRG pour rechange
18	Rod packing	NBR	VRG code for replacement	18	Joint tige	NBR	Code VRG pour rechange
19	Washer	Steel	VRG code for replacement	19	Rondelle	Acier	Code VRG pour rechange
20	Washer	Steel	VRG code for replacement	20	Rondelle	Acier	Code VRG pour rechange
21	U-nut	Steel	VRG code for replacement	21	Écrou	Acier	Code VRG pour rechange
22	C-shape snap ring	Steel	VRG code for replacement	22	Anneau de serrage	Acier	Code VRG pour rechange
23	Clip	Stainless steel	VRG code for replacement	23	Anneau	Acier inox	Code VRG pour rechange
24	R-shape snap ring	Steel	VRG code for replacement	24	Anneau de serrage	Acier	Code VRG pour rechange

**Schema di controllo • Control diagram •
Kontrollschema • Schéma de contrôle**

Scanalature per inserimento sensore • Auto switch housing
Nut zur Einführung des Sensors • Fente pour insérer le détecteur

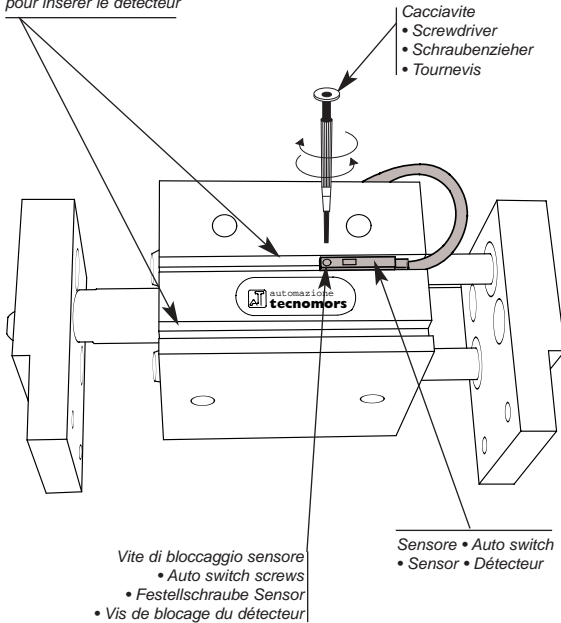

**Schema di montaggio • Mounting
• Montageschema • Schéma de montage**

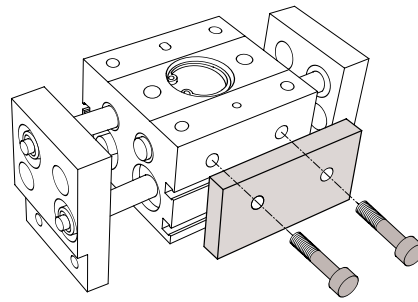

**Montaggio laterale • Side mounting •
Montage latéral • Seitliche Montage**

**Montaggio assiale
Fissaggio da sotto**

• Axial mounting
Bottom fixing

• Montage axial
Fixation inférieure

• Achsenrechte Montage
Befestigung von unten

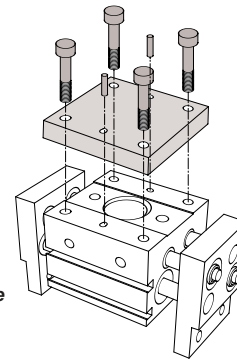

**Alimentazione pneumatica • Pneumatic feed •
Pneumatische Zuführung • Alimentation pneumatique**

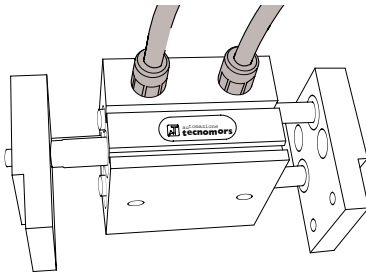

**Applicazione dita di presa • Finger application
• Anbringung der Greiffinger
• Application des doigts de préhension**

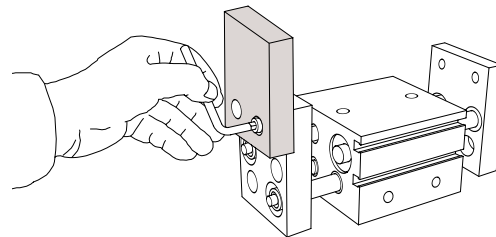

**Schema di presa • Gripping
• Greifschema • Schéma de préhension**

Esempi di serraggio • Clamping examples
• Aufspannbeispiele • Exemples de serrage

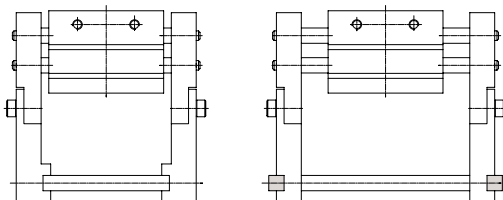

Serraggio esterno.
• External clamping.
• Außenaufspannen.
• Serrage externe.

Serraggio interno.
• Internal clamping.
• Innenaufspannen.
• Serrage interne.

Norme per la scelta del modello di organo di presa rispetto al componente da serrare.

La scelta del modello corretto dipende dal peso del componente, dal coefficiente di attrito fra le dita di presa ed il pezzo e dalla rispettiva conformazione.

L'organo di presa idoneo deve avere una forza di serraggio compresa fra 10 e 20 volte il peso del pezzo.

In caso di elevata accelerazione o decelerazione oppure si verifichi un impatto durante il trasporto del componente è opportuno considerare un adeguato margine di sicurezza.

Guidelines for the selection of air chuck model with respect to the component weight.

Selection of the correct model depends upon the component weight, the coefficient of friction between the chuck attachment and the component, and their respective configurations.

A model should be selected with a holding force of 10 to 20 times that of the component weight.

If high acceleration, high deceleration or impact are encountered during component transportation then a further margin of safety should be considered.

Normen zur Wahl des Greifermodells je nach auszuspannendem Werkstück.

Die richtige Wahl hängt vom Gewicht der Komponente, vom Reibwert zwischen den Greiffingern und dem Werkstück und von der entsprechenden Form ab.

Der geeignete Greifer muß eine Spannkraft besitzen, die 10 bis 20 mal das Gewicht des Werkstückes beträgt.

Im Falle einer hohen Beschleunigung oder einer starken Verlangsamung, oder sollte es während der Beförderung des Werkstückes zu einem Aufprall kommen, sollte man eine Sicherheitsgrenze in Betracht ziehen.

Normes pour le choix du modèle d'organe de préhension selon la pièce à serrer.

Le choix du bon modèle dépend du poids de la pièce, du coefficient de frottement entre les doigts de préhension et la pièce et des formes respectives.

L'organe de préhension correct doit avoir une force de serrage comprise entre 10 et 20 fois le poids de la pièce.

En cas de grande accélération ou décélération, ou en cas de choc pendant le transport de la pièce, prévoir une marge de sécurité plus grande.



- **ORGANO DI PRESA A CORSA PARALLELA A DUE GRIFFE**
- **Two-jaw parallel gripper**
- **Zwei-Finger Parallelgreifer**
- **Pince de préhension à course parallèle, à deux griffes**

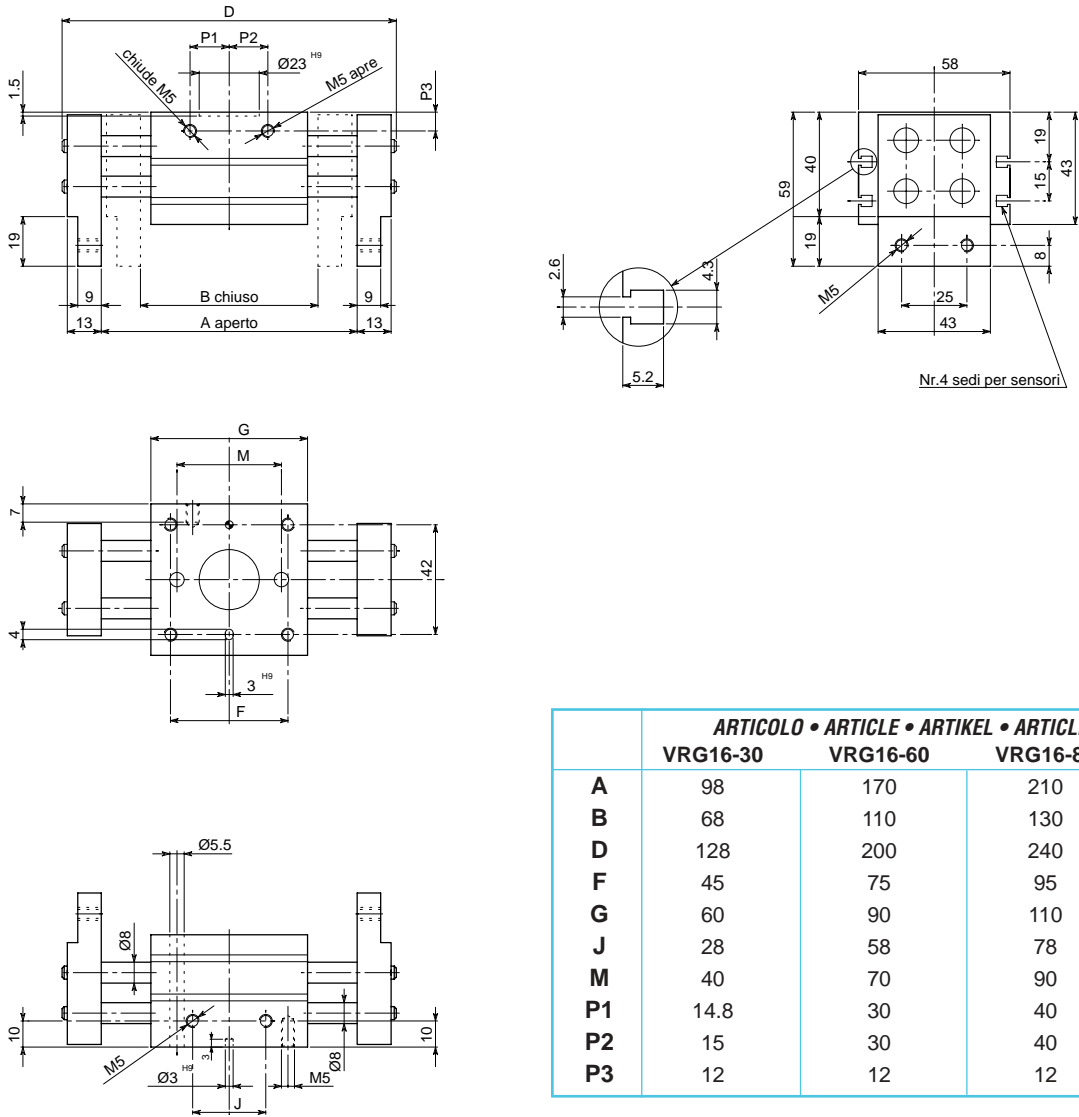

VRG 40

VRG 32

VRG 25

VRG 20

VRG 16

	ARTICOLO • ARTICLE • ARTIKEL • ARTICLE		
	VRG16-30	VRG16-60	VRG16-80
A	98	170	210
B	68	110	130
D	128	200	240
F	45	75	95
G	60	90	110
J	28	58	78
M	40	70	90
P1	14.8	30	40
P2	15	30	40
P3	12	12	12

• Le dimensioni sono indicative e suscettibili di variazioni per migliorie tecniche. Ci riserviamo di apportare modifiche senza preavviso • All dimensions are indicative and subject to variation for technical upgrading. We reserve the right to make alterations without prior notification • Die Maßangaben sind indikativ und können sich bei technischen Verbesserung ändern. Wir behalten uns vor, ohne vorherige Benachrichtigung Änderungen vorzunehmen • Les dimensions sont fournies à titre indicatif; elles peuvent subir des variations pour cause d'améliorations techniques. Nous nous réservons le droit d'apporter des modifications sans préavis.

- **SCHEMA DI FUNZIONAMENTO • OPERATIONAL DIAGRAM**
- **BETRIEBSSCHEMA • SCHÉMA DE FONCTIONNEMENT**

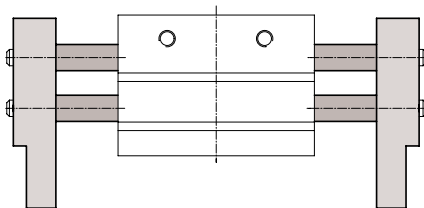

Aperto
Open
Geöffnet
Ouvert

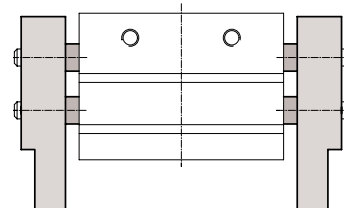

Chiuso
Closed
Geschlossen
Fermé

- **ORGANO DI PRESA A CORSA PARALLELA A DUE GRIFFE**
- **Two-jaw parallel gripper**
- **Zwei-Finger Parallelgreifer**
- **Pince de préhension à course parallèle, à deux griffes**

DIAGRAMMA FORZA DI CHIUSURA
CLAMPING FORCE DIAGRAM • DIAGRAM SCHLIEßKRAFT
DIAGRAMME DE LA FORCE DE FERMETURE

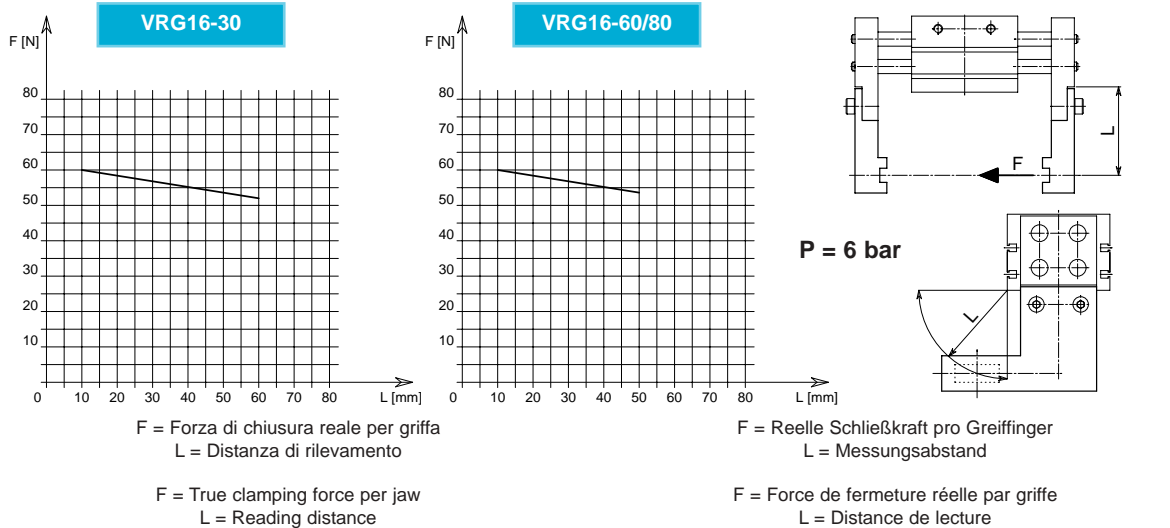

Valori nei dati tecnici rilevati alla distanza L = 10 mm • Technical specification values read at a distance L = 10 mm

• Werte der technischen Daten auf Distanz aufgenommen L = 10 mm • Valeurs des données techniques relevées à la distance L = 10 mm

DATI TECNICI VRG16	30	60	80
Corsa per griffa (mm)	.15	.30	.40
Corsa pistone (mm)	.15	.30	.40
Volume aria doppia corsa (cm ³)	.9.1	.18.2	.24.2
Forza teorica di chiusura per griffa a 6 bar (N)	.89	.89	.89
Forza reale di chiusura per griffa a 6 bar (N)	.60	.60	.60
Forza teorica di apertura per griffa a 6 bar (N)	.89	.89	.89
Forza reale di apertura per griffa a 6 bar (N)	.60	.60	.60
Pressione di esercizio (bar)	.1-6	.1-6	.1-6
Ripetibilità (mm)	.±0.1	.±0.1	.±0.1
Peso (Kg)	.0.585	.0.795	.0.935
Temperatura di esercizio (°C)	.-10-60	.-10-60	.-10-60
Codice articolo	.VG100ABA	.VG100ABB	.VG100ABC

SPECIFICATIONS VRG16	30	60	80
Stroke per jaw (mm)	.15	.30	.40
Piston stroke (mm)	.15	.30	.40
Dual stroke air volume (cm ³)	.9.1	.18.2	.24.2
Theoretical clamping force per jaw at 6 bar (N)	.89	.89	.89
Actual clamping force per jaw at 6 bar (N)	.60	.60	.60
Theoretical opening force per jaw at 6 bar (N)	.89	.89	.89
Actual opening force per jaw at 6 bar (N)	.60	.60	.60
Working pressure (bar)	.1-6	.1-6	.1-6
Reproducibility (mm)	.±0.1	.±0.1	.±0.1
Weight (Kg)	.0.585	.0.795	.0.935
Working temperature (°C)	.-10-60	.-10-60	.-10-60
Article code	.VG100ABA	.VG100ABB	.VG100ABC

TECHNISCHE DATEN VRG16	30	60	80
Hub pro Greiffinger (mm)	.15	.30	.40
Kolbenhub (mm)	.15	.30	.40
Luftvolumen pro Doppelhub (cm ³)	.9.1	.18.2	.24.2
Theoretische Schließkraft pro Greiffinger 6 bar (N)	.89	.89	.89
Reelle Schließkraft pro Greiffinger 6 bar (N)	.60	.60	.60
Theoretische Öffnungskraft pro Greiffinger 6 bar (N)	.89	.89	.89
Reelle Öffnungskraft pro Greiffinger 6 bar (N)	.60	.60	.60
Betriebsdruck (bar)	.1-6	.1-6	.1-6
Wiederholbarkeit (mm)	.±0.1	.±0.1	.±0.1
Gewicht (Kg)	.0.585	.0.795	.0.935
Betriebstemperatur (°C)	.-10-60	.-10-60	.-10-60
Artikelcode	.VG100ABA	.VG100ABB	.VG100ABC

DONNÉES TECHNIQUES VRG16	30	60	80
Course par griffe (mm)	.15	.30	.40
Course piston (mm)	.15	.30	.40
Volume d'air pour course double (cm ³)	.9.1	.18.2	.24.2
Force théorique en fermeture par griffe à 6 bar (N)	.89	.89	.89
Force réelle en fermeture par griffe à 6 bar (N)	.60	.60	.60
Force théorique en ouverture par griffe à 6 bar (N)	.89	.89	.89
Force réelle en ouverture par griffe à 6 bar (N)	.60	.60	.60
Pression d'exercice (bar)	.1-6	.1-6	.1-6
Répétibilité (mm)	.±0.1	.±0.1	.±0.1
Poids (Kg)	.0.585	.0.795	.0.935
Température d'exercice (°C)	.-10-60	.-10-60	.-10-60
Code article	.VG100ABA	.VG100ABB	.VG100ABC

VRG 40

VRG 32

VRG 25

VRG 20

VRG 16



- **ORGANO DI PRESA A CORSA PARALLELA A DUE GRIFFE**
- **Two-jaw parallel gripper**
- **Zwei-Finger Parallelgreifer**
- **Pince de préhension à course parallèle, à deux griffes**

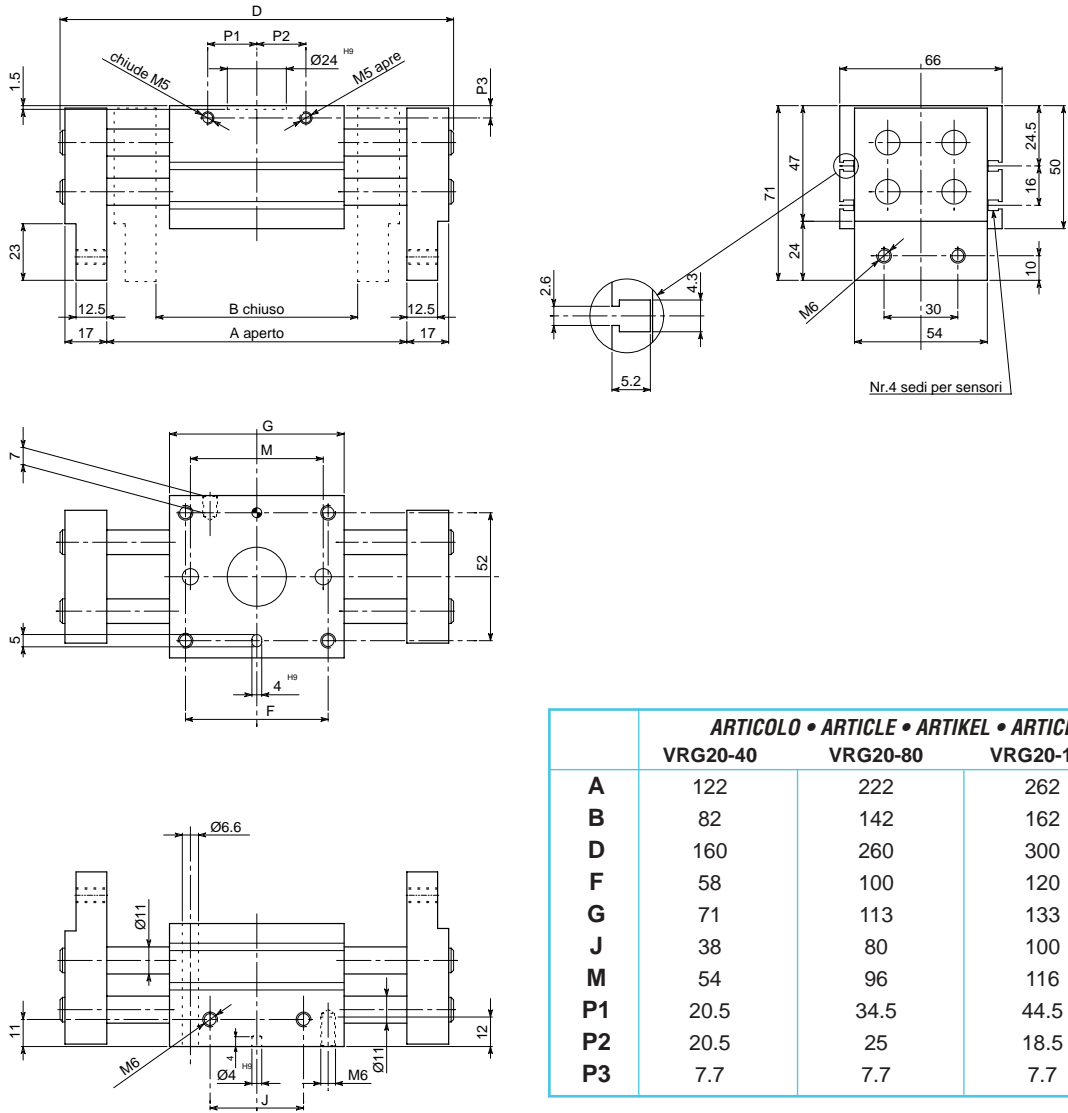

	ARTICOLO • ARTICLE • ARTIKEL • ARTICLE		
	VRG20-40	VRG20-80	VRG20-100
A	122	222	262
B	82	142	162
D	160	260	300
F	58	100	120
G	71	113	133
J	38	80	100
M	54	96	116
P1	20.5	34.5	44.5
P2	20.5	25	18.5
P3	7.7	7.7	7.7

• Le dimensioni sono indicative e suscettibili di variazioni per migliorie tecniche. Ci riserviamo di apportare modifiche senza preavviso • All dimensions are indicative and subject to variation for technical upgrading. We reserve the right to make alterations without prior notification • Die Maßangaben sind indikativ und können sich bei technischen Verbesserung ändern. Wir behalten uns vor, ohne vorherige Benachrichtigung Änderungen vorzunehmen • Les dimensions sont fournies à titre indicatif; elles peuvent subir des variations pour cause d'améliorations techniques. Nous nous réservons le droit d'apporter des modifications sans préavis.

• **SCHEMA DI FUNZIONAMENTO • OPERATIONAL DIAGRAM**
 • **BETRIEBSSCHEMA • SCHÉMA DE FONCTIONNEMENT**

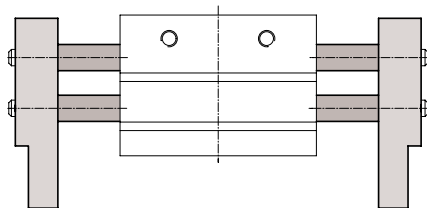

Aperto
Open
Geöffnet
Ouvert

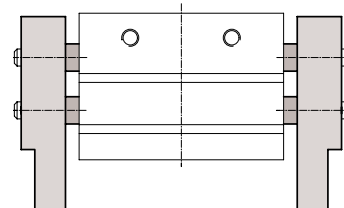

Chiuso
Closed
Geschlossen
Fermé

VRG 40

VRG 32

VRG 25

VRG 20

VRG 16

- **ORGANO DI PRESA A CORSA PARALLELA A DUE GRIFFE**
- **Two-jaw parallel gripper**
- **Zwei-Finger Parallelgreifer**
- **Pince de préhension à course parallèle, à deux griffes**

DIAGRAMMA FORZA DI CHIUSURA
CLAMPING FORCE DIAGRAM • DIAGRAM SCHLIEßKRAFT
DIAGRAMME DE LA FORCE DE FERMETURE

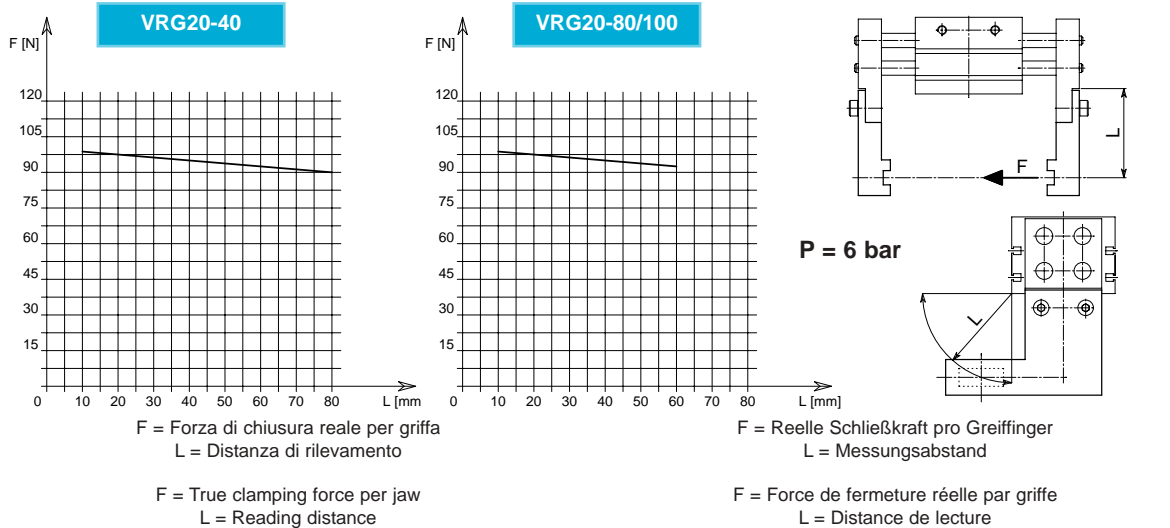

Valori nei dati tecnici rilevati alla distanza L = 10 mm • Technical specification values read at a distance L = 10 mm

• Werte der technischen Daten auf Distanz aufgenommen L = 10 mm • Valeurs des données techniques relevées à la distance L = 10 mm

DATI TECNICI VRG20	40	80	100
Corsa per griffa (mm)	.20	.40	.50
Corsa pistone (mm)	.20	.40	.50
Volume aria doppia corsa (cm ³)	17.6	35.2	44
Forza teorica di chiusura per griffa a 6 bar (N)	129	129	129
Forza reale di chiusura per griffa a 6 bar (N)	100	100	100
Forza teorica di apertura per griffa a 6 bar (N)	129	129	129
Forza reale di apertura per griffa a 6 bar (N)	100	100	100
Pressione di esercizio (bar)	1-6	1-6	1-6
Ripetibilità (mm)	±0.1	±0.1	±0.1
Peso (Kg)	1.025	1.495	1.69
Temperatura di esercizio (°C)	-10-60	-10-60	-10-60
Codice articolo	VG100ABD	VG100ABE	VG100ABF

SPECIFICATIONS VRG20	40	80	100
Stroke per jaw (mm)	.20	.40	.50
Piston stroke (mm)	.20	.40	.50
Dual stroke air volume (cm ³)	17.6	35.2	44
Theoretical clamping force per jaw at 6 bar (N)	129	129	129
Actual clamping force per jaw at 6 bar (N)	100	100	100
Theoretical opening force per jaw at 6 bar (N)	129	129	129
Actual opening force per jaw at 6 bar (N)	100	100	100
Working pressure (bar)	1-6	1-6	1-6
Reproducibility (mm)	±0.1	±0.1	±0.1
Weight (Kg)	1.025	1.495	1.69
Working temperature (°C)	-10-60	-10-60	-10-60
Article code	VG100ABD	VG100ABE	VG100ABF

TECHNISCHE DATEN VRG20	40	80	100
Hub pro Greiffinger (mm)	.20	.40	.50
Kolbenhub (mm)	.20	.40	.50
Luftvolumen pro Doppelhub (cm ³)	17.6	35.2	44
Theoretische Schließkraft pro Greiffinger 6 bar (N)	129	129	129
Reelle Schließkraft pro Greiffinger 6 bar (N)	100	100	100
Theoretische Öffnungskraft pro Greiffinger 6 bar (N)	129	129	129
Reelle Öffnungskraft pro Greiffinger 6 bar (N)	100	100	100
Betriebsdruck (bar)	1-6	1-6	1-6
Wiederholbarkeit (mm)	±0.1	±0.1	±0.1
Gewicht (Kg)	1.025	1.495	1.69
Betriebstemperatur (°C)	-10-60	-10-60	-10-60
Artikelcode	VG100ABD	VG100ABE	VG100ABF

DONNÉES TECHNIQUES VRG20	40	80	100
Course par griffe (mm)	.20	.40	.50
Course piston (mm)	.20	.40	.50
Volume d'air pour course double (cm ³)	17.6	35.2	44
Force théorique en fermeture par griffe à 6 bar (N)	129	129	129
Force réelle en fermeture par griffe à 6 bar (N)	100	100	100
Force théorique en ouverture par griffe à 6 bar (N)	129	129	129
Force réelle en ouverture par griffe à 6 bar (N)	100	100	100
Pression d'exercice (bar)	1-6	1-6	1-6
Répétibilité (mm)	±0.1	±0.1	±0.1
Poids (Kg)	1.025	1.495	1.69
Température d'exercice (°C)	-10-60	-10-60	-10-60
Code article	VG100ABD	VG100ABE	VG100ABF

VRG 40

VRG 32

VRG 25

VRG 20

VRG 16



- **ORGANO DI PRESA A CORSA PARALLELA A DUE GRIFFE**
- **Two-jaw parallel gripper**
- **Zwei-Finger Parallelgreifer**
- **Pince de préhension à course parallèle, à deux griffes**

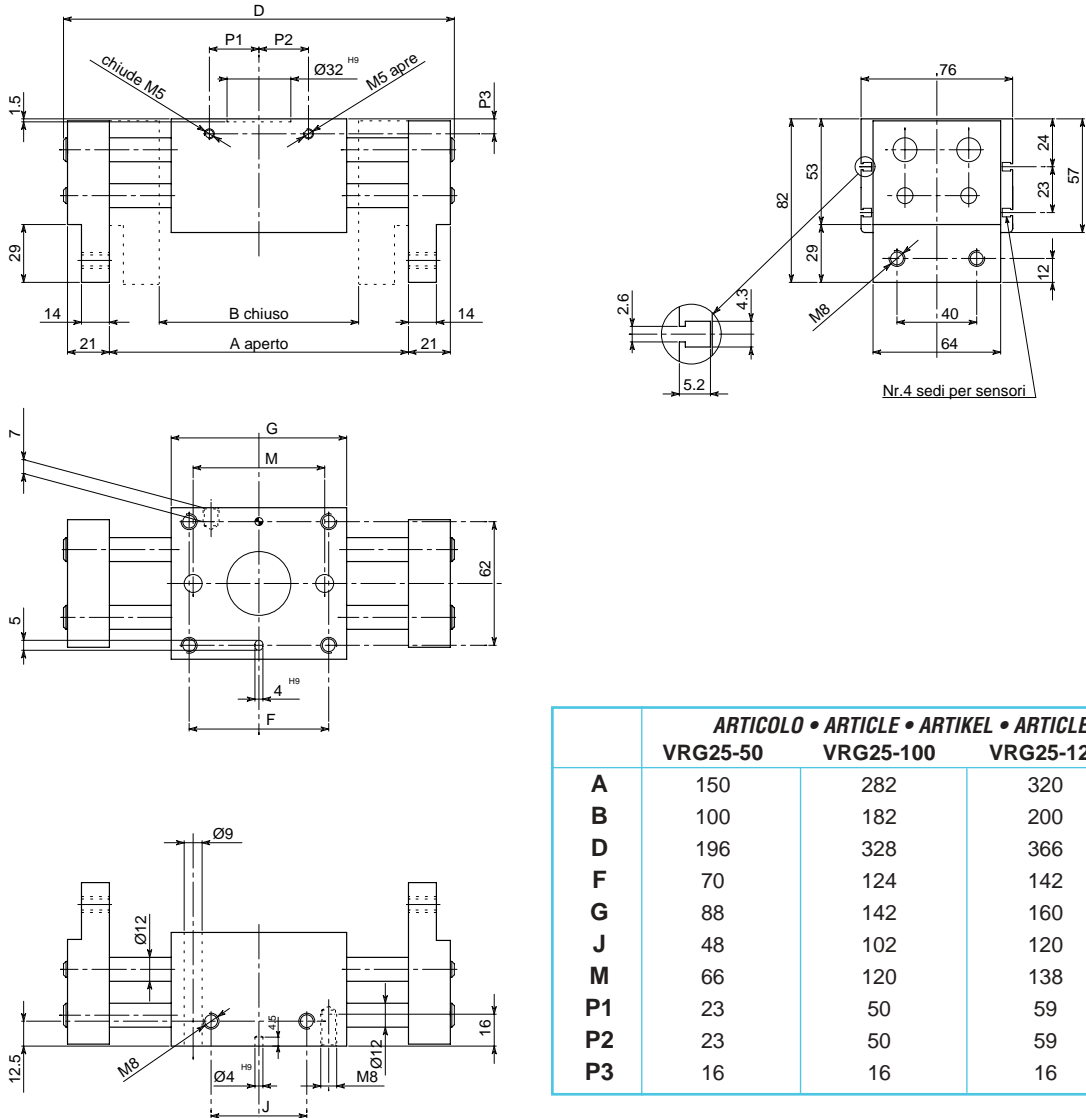

	ARTICOLO • ARTICLE • ARTIKEL • ARTICLE		
	VRG25-50	VRG25-100	VRG25-120
A	150	282	320
B	100	182	200
D	196	328	366
F	70	124	142
G	88	142	160
J	48	102	120
M	66	120	138
P1	23	50	59
P2	23	50	59
P3	16	16	16

• Le dimensioni sono indicative e suscettibili di variazioni per migliorie tecniche. Ci riserviamo di apportare modifiche senza preavviso • All dimensions are indicative and subject to variation for technical upgrading. We reserve the right to make alterations without prior notification • Die Maßangaben sind indikativ und können sich bei technischen Verbesserung ändern. Wir behalten uns vor, ohne vorherige Benachrichtigung Änderungen vorzunehmen • Les dimensions sont fournies à titre indicatif; elles peuvent subir des variations pour cause d'améliorations techniques. Nous nous réservons le droit d'apporter des modifications sans préavis.

• **SCHEMA DI FUNZIONAMENTO • OPERATIONAL DIAGRAM**
 • **BETRIEBSSCHEMA • SCHÉMA DE FONCTIONNEMENT**

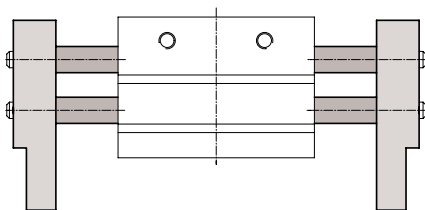

Aperto
Open
Geöffnet
Ouvert

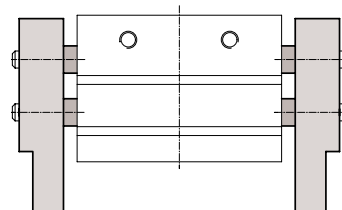

Chiuso
Closed
Geschlossen
Fermé

- **ORGANO DI PRESA A CORSA PARALLELA A DUE GRIFFE**
- **Two-jaw parallel gripper**
- **Zwei-Finger Parallelgreifer**
- **Pince de préhension à course parallèle, à deux griffes**

DIAGRAMMA FORZA DI CHIUSURA
CLAMPING FORCE DIAGRAM • DIAGRAM SCHLIEßKRAFT
DIAGRAMME DE LA FORCE DE FERMETURE

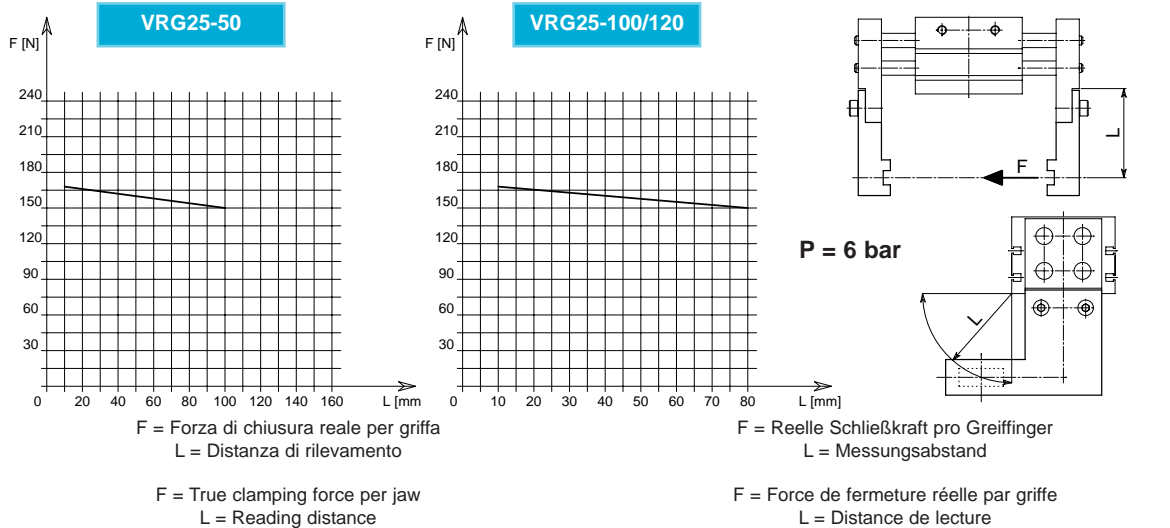

Valori nei dati tecnici rilevati alla distanza L = 10 mm • Technical specification values read at a distance L = 10 mm

• Werte der technischen Daten auf Distanz aufgenommen L = 10 mm • Valeurs des données techniques relevées à la distance L = 10 mm

DATI TECNICI VRG25	50	100	120
Corsa per griffa (mm)	.25	.50	.60
Corsa pistone (mm)	.25	.50	.60
Volume aria doppia corsa (cm ³)	.38	.76	.91.2
Forza teorica di chiusura per griffa a 6 bar (N)	.223	.223	.223
Forza reale di chiusura per griffa a 6 bar (N)	.170	.170	.170
Forza teorica di apertura per griffa a 6 bar (N)	.223	.223	.223
Forza reale di apertura per griffa a 6 bar (N)	.170	.170	.170
Pressione di esercizio (bar)	.1-6	.1-6	.1-6
Ripetibilità (mm)	±0.1	±0.1	±0.1
Peso (Kg)	.1.69	.2.56	.2.775
Temperatura di esercizio (°C)	-10-60	-10-60	-10-60
Codice articolo	.VG100ABG	.VG100ABH	.VG100ABI

SPECIFICATIONS VRG25	50	100	120
Stroke per jaw (mm)	.25	.50	.60
Piston stroke (mm)	.25	.50	.60
Dual stroke air volume (cm ³)	.38	.76	.91.2
Theoretical clamping force per jaw at 6 bar (N)	.223	.223	.223
Actual clamping force per jaw at 6 bar (N)	.170	.170	.170
Theoretical opening force per jaw at 6 bar (N)	.223	.223	.223
Actual opening force per jaw at 6 bar (N)	.170	.170	.170
Working pressure (bar)	.1-6	.1-6	.1-6
Reproducibility (mm)	±0.1	±0.1	±0.1
Weight (Kg)	.1.69	.2.56	.2.775
Working temperature (°C)	-10-60	-10-60	-10-60
Article code	.VG100ABG	.VG100ABH	.VG100ABI

TECHNISCHE DATEN VRG25	50	100	120
Hub pro Greiffinger (mm)	.25	.50	.60
Kolbenhub (mm)	.25	.50	.60
Luftvolumen pro Doppelhub (cm ³)	.38	.76	.91.2
Theoretische Schließkraft pro Greiffinger 6 bar (N)	.223	.223	.223
Reelle Schließkraft pro Greiffinger 6 bar (N)	.170	.170	.170
Theoretische Öffnungskraft pro Greiffinger 6 bar (N)	.223	.223	.223
Reelle Öffnungskraft pro Greiffinger 6 bar (N)	.170	.170	.170
Betriebsdruck (bar)	.1-6	.1-6	.1-6
Wiederholbarkeit (mm)	±0.1	±0.1	±0.1
Gewicht (Kg)	.1.69	.2.56	.2.775
Betriebstemperatur (°C)	-10-60	-10-60	-10-60
Artikelcode	.VG100ABG	.VG100ABH	.VG100ABI

DONNÉES TECHNIQUES VRG25	50	100	120
Course par griffe (mm)	.25	.50	.60
Course piston (mm)	.25	.50	.60
Volume d'air pour course double (cm ³)	.38	.76	.91.2
Force théorique en fermeture par griffe à 6 bar (N)	.223	.223	.223
Force réelle en fermeture par griffe à 6 bar (N)	.170	.170	.170
Force théorique en ouverture par griffe à 6 bar (N)	.223	.223	.223
Force réelle en ouverture par griffe à 6 bar (N)	.170	.170	.170
Pression d'exercice (bar)	.1-6	.1-6	.1-6
Répétibilité (mm)	±0.1	±0.1	±0.1
Poids (Kg)	.1.69	.2.56	.2.775
Température d'exercice (°C)	-10-60	-10-60	-10-60
Code article	.VG100ABG	.VG100ABH	.VG100ABI

VRG 40

VRG 32

VRG 25

VRG 20

VRG 16



- **ORGANO DI PRESA A CORSA PARALLELA A DUE GRIFFE**
- **Two-jaw parallel gripper**
- **Zwei-Finger Parallelgreifer**
- **Pince de préhension à course parallèle, à deux griffes**

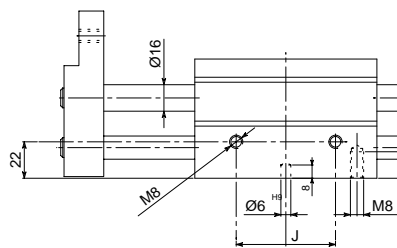
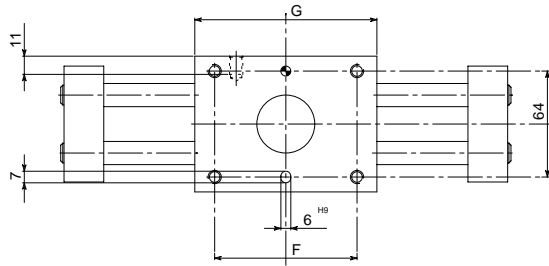
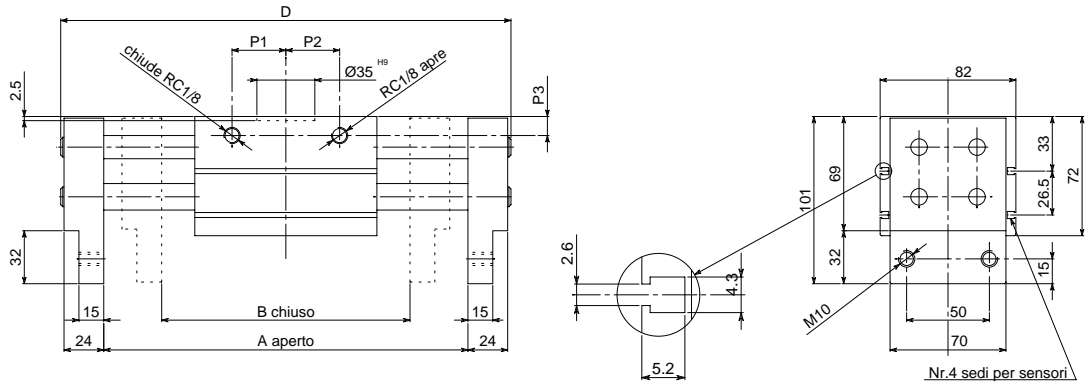

	ARTICOLO • ARTICLE • ARTIKEL • ARTICLE		
	VRG32-70	VRG32-120	VRG32-160
A	220	318	402
B	150	198	242
D	272	370	454
F	86	134	178
G	110	158	202
J	60	108	152
P1	23.5	47.5	69.5
P2	23.5	47.5	69.5
P3	18.2	18.2	18.2

• Le dimensioni sono indicative e suscettibili di variazioni per migliorie tecniche. Ci riserviamo di apportare modifiche senza preavviso • All dimensions are indicative and subject to variation for technical upgrading. We reserve the right to make alterations without prior notification • Die Maßangaben sind indikativ und können sich bei technischen Verbesserung ändern. Wir behalten uns vor, ohne vorherige Benachrichtigung Änderungen vorzunehmen • Les dimensions sont fournies à titre indicatif; elles peuvent subir des variations pour cause d'améliorations techniques. Nous nous réservons le droit d'apporter des modifications sans préavis.

• **SCHEMA DI FUNZIONAMENTO • OPERATIONAL DIAGRAM**
 • **BETRIEBSSCHEMA • SCHÉMA DE FONCTIONNEMENT**

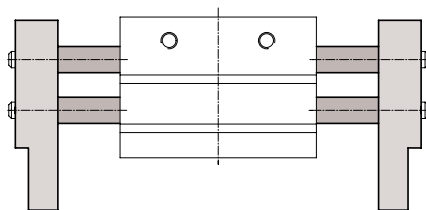

Aperto
Open
Geöffnet
Ouvert

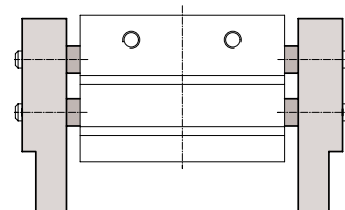

Chiuso
Closed
Geschlossen
Fermé

VRG 40

VRG 32

VRG 25

VRG 20

VRG 16

- **ORGANO DI PRESA A CORSA PARALLELA A DUE GRIFFE**
- **Two-jaw parallel gripper**
- **Zwei-Finger Parallelgreifer**
- **Pince de préhension à course parallèle, à deux griffes**

DIAGRAMMA FORZA DI CHIUSURA
CLAMPING FORCE DIAGRAM • DIAGRAM SCHLIEßKRAFT
DIAGRAMME DE LA FORCE DE FERMETURE

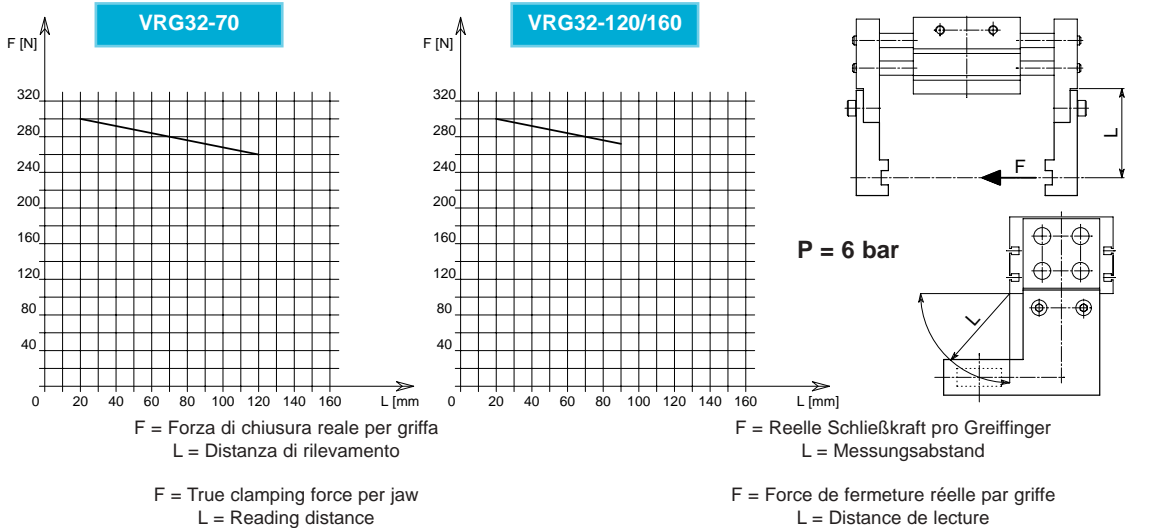

Valori nei dati tecnici rilevati alla distanza L = 20 mm • Technical specification values read at a distance L = 20 mm

• Werte der technischen Daten auf Distanz aufgenommen L = 20 mm • Valeurs des données techniques relevées à la distance L = 20 mm

DATI TECNICI VRG32	70	120	160
Corsa per griffa (mm)	.35	.60	.80
Corsa pistone (mm)	.35	.60	.80
Volume aria doppia corsa (cm ³)	.84.5	.145	.193
Forza teorica di chiusura per griffa a 6 bar (N)	.355	.355	.355
Forza reale di chiusura per griffa a 6 bar (N)	.300	.300	.300
Forza teorica di apertura per griffa a 6 bar (N)	.355	.355	.355
Forza reale di apertura per griffa a 6 bar (N)	.300	.300	.300
Pressione di esercizio (bar)	.1-6	.1-6	.1-6
Ripetibilità (mm)	±0.1	±0.1	±0.1
Peso (Kg)	.2.905	.3.82	.4.655
Temperatura di esercizio (°C)	.-10-60	.-10-60	.-10-60
Codice articolo	.VG100ABL	.VG100ABM	.VG100ABN

SPECIFICATIONS VRG32	70	120	160
Stroke per jaw (mm)	.35	.60	.80
Piston stroke (mm)	.35	.60	.80
Dual stroke air volume (cm ³)	.84.5	.145	.193
Theoretical clamping force per jaw at 6 bar (N)	.355	.355	.355
Actual clamping force per jaw at 6 bar (N)	.300	.300	.300
Theoretical opening force per jaw at 6 bar (N)	.355	.355	.355
Actual opening force per jaw at 6 bar (N)	.300	.300	.300
Working pressure (bar)	.1-6	.1-6	.1-6
Reproducibility (mm)	±0.1	±0.1	±0.1
Weight (Kg)	.2.905	.3.82	.4.655
Working temperature (°C)	.-10-60	.-10-60	.-10-60
Article code	.VG100ABL	.VG100ABM	.VG100ABN

TECHNISCHE DATEN VRG32	70	120	160
Hub pro Greiffinger (mm)	.35	.60	.80
Kolbenhub (mm)	.35	.60	.80
Luftvolumen pro Doppelhub (cm ³)	.84.5	.145	.193
Theoretische Schließkraft pro Greiffinger 6 bar (N)	.355	.355	.355
Reelle Schließkraft pro Greiffinger 6 bar (N)	.300	.300	.300
Theoretische Öffnungskraft pro Greiffinger 6 bar (N)	.355	.355	.355
Reelle Öffnungskraft pro Greiffinger 6 bar (N)	.300	.300	.300
Betriebsdruck (bar)	.1-6	.1-6	.1-6
Wiederholbarkeit (mm)	±0.1	±0.1	±0.1
Gewicht (Kg)	.2.905	.3.82	.4.655
Betriebstemperatur (°C)	.-10-60	.-10-60	.-10-60
Artikelcode	.VG100ABL	.VG100ABM	.VG100ABN

DONNÉES TECHNIQUES VRG32	70	120	160
Course par griffe (mm)	.35	.60	.80
Course piston (mm)	.35	.60	.80
Volume d'air pour course double (cm ³)	.84.5	.145	.193
Force théorique en fermeture par griffe à 6 bar (N)	.355	.355	.355
Force réelle en fermeture par griffe à 6 bar (N)	.300	.300	.300
Force théorique en ouverture par griffe à 6 bar (N)	.355	.355	.355
Force réelle en ouverture par griffe à 6 bar (N)	.300	.300	.300
Pression d'exercice (bar)	.1-6	.1-6	.1-6
Répétibilité (mm)	±0.1	±0.1	±0.1
Poids (Kg)	.2.905	.3.82	.4.655
Température d'exercice (°C)	.-10-60	.-10-60	.-10-60
Code article	.VG100ABL	.VG100ABM	.VG100ABN

VRG 40

VRG 32

VRG 25

VRG 20

VRG 16



- **ORGANO DI PRESA A CORSA PARALLELA A DUE GRIFFE**
- **Two-jaw parallel gripper**
- **Zwei-Finger Parallelgreifer**
- **Pince de préhension à course parallèle, à deux griffes**

VRG 40

VRG 32

VRG 25

VRG 20

VRG 16

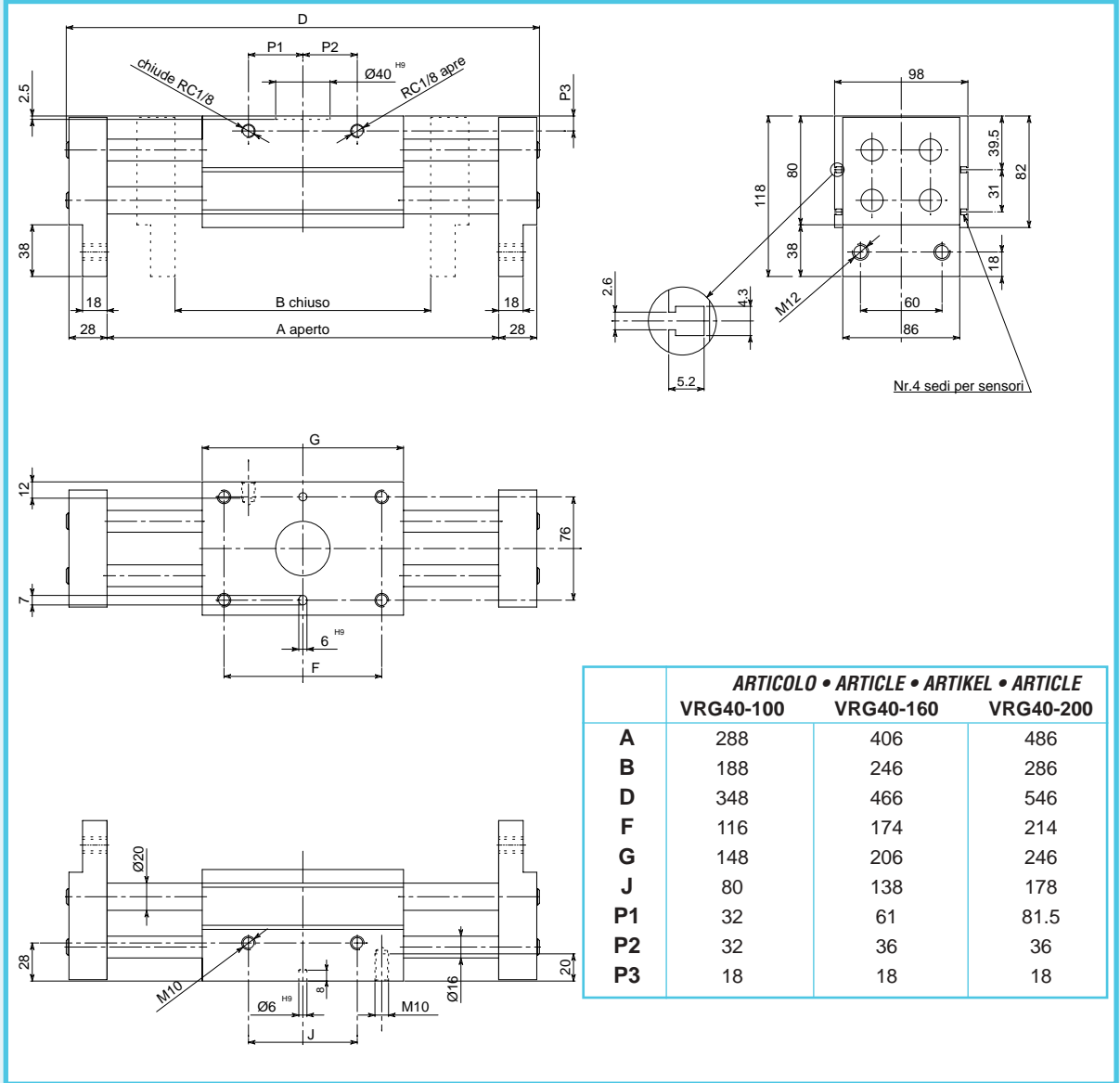

• Le dimensioni sono indicative e suscettibili di variazioni per migliorie tecniche. Ci riserviamo di apportare modifiche senza preavviso • All dimensions are indicative and subject to variation for technical upgrading. We reserve the right to make alterations without prior notification • Die Maßangaben sind indikativ und können sich bei technischen Verbesserungen ändern. Wir behalten uns vor, ohne vorherige Benachrichtigung Änderungen vorzunehmen • Les dimensions sont fournies à titre indicatif; elles peuvent subir des variations pour cause d'améliorations techniques. Nous nous réservons le droit d'apporter des modifications sans préavis.

- **SCHEMA DI FUNZIONAMENTO • OPERATIONAL DIAGRAM**
- **BETRIEBSSCHEMA • SCHÉMA DE FONCTIONNEMENT**

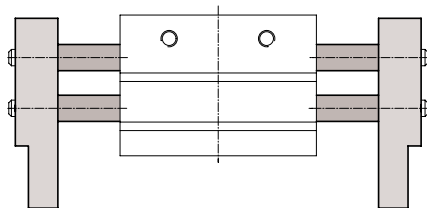

Aperto
Open
Geöffnet
Ouvert

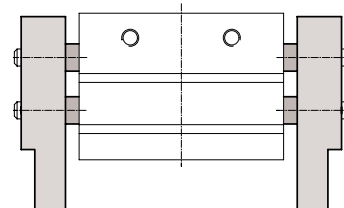

Chiuso
Closed
Geschlossen
Fermé

- **ORGANO DI PRESA A CORSA PARALLELA A DUE GRIFFE**
- **Two-jaw parallel gripper**
- **Zwei-Finger Parallelgreifer**
- **Pince de préhension à course parallèle, à deux griffes**

DIAGRAMMA FORZA DI CHIUSURA
CLAMPING FORCE DIAGRAM • DIAGRAM SCHLIEßKRAFT
DIAGRAMME DE LA FORCE DE FERMETURE

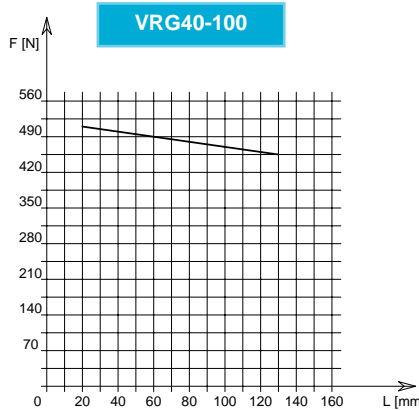

F = Forza di chiusura reale per griffa
 L = Distanza di rilevamento

F = True clamping force per jaw
 L = Reading distance

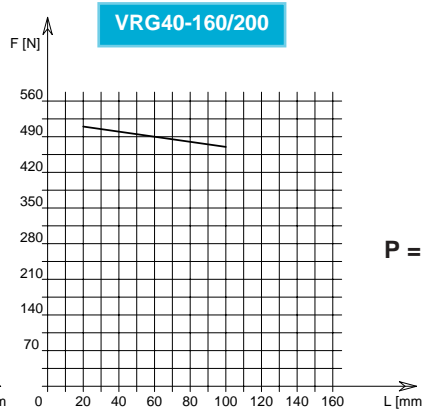

F = Reelle Schließkraft pro Greiffinger
 L = Messungsabstand

F = Force de fermeture réelle par griffe
 L = Distance de lecture

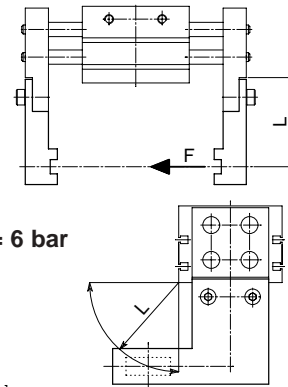

Valori nei dati tecnici rilevati alla distanza L = 20 mm • Technical specification values read at a distance L = 20 mm
 • Werte der technischen Daten auf Distanz aufgenommen L = 20 mm • Valeurs des données techniques relevées à la distance L = 20 mm

DATI TECNICI VRG40	100	160	200
Corsa per griffa (mm)	.50	.80	.100
Corsa pistone (mm)	.50	.80	.100
Volume aria doppia corsa (cm ³)	.188.5	.302	.377
Forza teorica di chiusura per griffa a 6 bar (N)	.554	.554	.554
Forza reale di chiusura per griffa a 6 bar (N)	.500	.500	.500
Forza teorica di apertura per griffa a 6 bar (N)	.554	.554	.554
Forza reale di apertura per griffa a 6 bar (N)	.500	.500	.500
Pressione di esercizio (bar)	.1-6	.1-6	.1-6
Ripetibilità (mm)	±0.1	±0.1	±0.1
Peso (Kg)	.5.27	.6.83	.7.905
Temperatura di esercizio (°C)	-10-60	-10-60	-10-60
Codice articolo	.VG100ABO	.VG100ABP	.VG100ABQ

SPECIFICATIONS VRG40	100	160	200
Stroke per jaw (mm)	.50	.80	.100
Piston stroke (mm)	.50	.80	.100
Dual stroke air volume (cm ³)	.188.5	.302	.377
Theoretical clamping force per jaw at 6 bar (N)	.554	.554	.554
Actual clamping force per jaw at 6 bar (N)	.500	.500	.500
Theoretical opening force per jaw at 6 bar (N)	.554	.554	.554
Actual opening force per jaw at 6 bar (N)	.500	.500	.500
Working pressure (bar)	.1-6	.1-6	.1-6
Reproducibility (mm)	±0.1	±0.1	±0.1
Weight (Kg)	.5.27	.6.83	.7.905
Working temperature (°C)	-10-60	-10-60	-10-60
Article code	.VG100ABO	.VG100ABP	.VG100ABQ

TECHNISCHE DATEN VRG40	100	160	200
Hub pro Greiffinger (mm)	.50	.80	.100
Kolbenhub (mm)	.50	.80	.100
Luftvolumen pro Doppelhub (cm ³)	.188.5	.302	.377
Theoretische Schließkraft pro Greiffinger 6 bar (N)	.554	.554	.554
Reelle Schließkraft pro Greiffinger 6 bar (N)	.500	.500	.500
Theoretische Öffnungskraft pro Greiffinger 6 bar (N)	.554	.554	.554
Reelle Öffnungskraft pro Greiffinger 6 bar (N)	.500	.500	.500
Betriebsdruck (bar)	.1-6	.1-6	.1-6
Wiederholbarkeit (mm)	±0.1	±0.1	±0.1
Gewicht (Kg)	.5.27	.6.83	.7.905
Betriebstemperatur (°C)	-10-60	-10-60	-10-60
Artikelcode	.VG100ABO	.VG100ABP	.VG100ABQ

DONNÉES TECHNIQUES VRG40	100	160	200
Course par griffe (mm)	.50	.80	.100
Course piston (mm)	.50	.80	.100
Volume d'air pour course double (cm ³)	.188.5	.302	.377
Force théorique en fermeture par griffe à 6 bar (N)	.554	.554	.554
Force réelle en fermeture par griffe à 6 bar (N)	.500	.500	.500
Force théorique en ouverture par griffe à 6 bar (N)	.554	.554	.554
Force réelle en ouverture par griffe à 6 bar (N)	.500	.500	.500
Pression d'exercice (bar)	.1-6	.1-6	.1-6
Répétibilité (mm)	±0.1	±0.1	±0.1
Poids (Kg)	.5.27	.6.83	.7.905
Température d'exercice (°C)	-10-60	-10-60	-10-60
Code article	.VG100ABO	.VG100ABP	.VG100ABQ

VRG 40

VRG 32

VRG 25

VRG 20

VRG 16



- **SENSORI PER CONTROLLO POSIZIONE CON LETTURA DEL MAGNETE INTEGRATO NEL PRODOTTO.**
- **Integrated magnet control position with switches.**
- **Integerter Magnet für Positionkontrolle mit Sensoren.**
- **Contrôle de la position avec détecteurs avec magnét intégrée.**

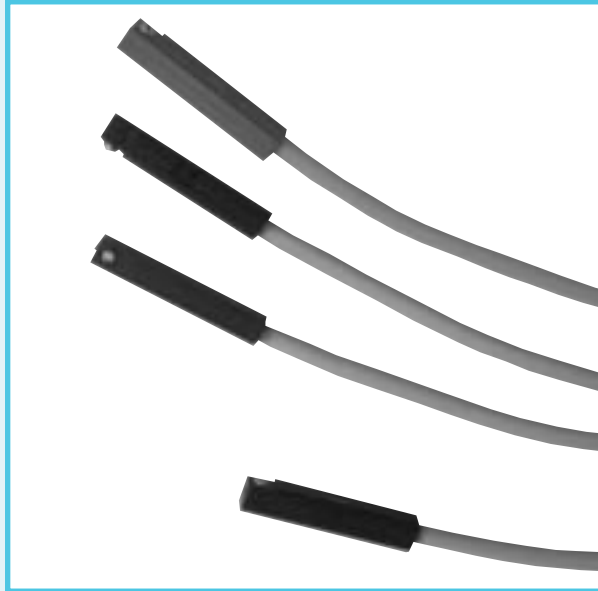

Sigla Code Bezeichnung Sigle	Tipo Typ Type Type	Tensione Voltage Spannung Tension	Corrente Current Strom Courant	Codice articolo Article code Artikelcode Code article
RH	REED	5-120V DC/AC	100 mA max	SE800RHO



- **NOTE**
- **Notes**
- **Anmerkungen**
- **Notes**

