



*Advanced Components  
for Automation*

**tecnomors**



organi di presa - grippers - greifer - organes de préhension

**engineering manual  
& design guide**



- **ORGANO DI PRESA A CORSA PARALLELA A TRE GRIFFE**
- **Three-jaw parallel gripper**
- **Drei-finger Parallelgreifer**
- **Pince de préhension à course parallèle, à trois griffes**

• Disegno OPE 60-3 • Drawing OPE 60-3 • Zeichnung OPE 60-3 • Dessin OPE 60-3

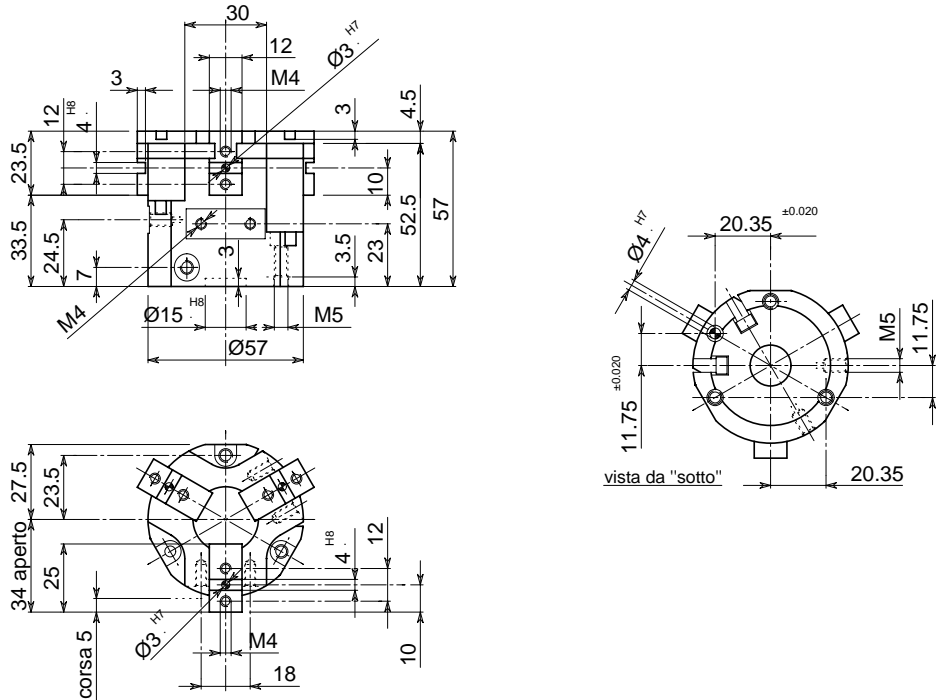

• Versione OPE 60-3 S • Version OPE 60-3 S • Ausführung OPE 60-3 S • Version OPE 60-3 S

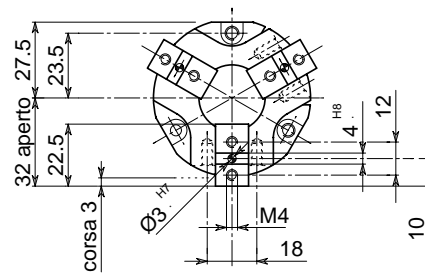

• Le dimensioni sono indicative e suscettibili di variazioni per migliorie tecniche. Ci riserviamo di apportare modifiche senza preavviso • All dimensions are indicative and subject to variation for technical upgrading. We reserve the right to make alterations without prior notification • Die Maßangaben sind indikativ und können sich bei technischen Verbesserungen ändern. Wir behalten uns vor, ohne vorherige Benachrichtigung Änderungen vorzunehmen • Les dimensions sont fournies à titre indicatif, elles peuvent subir des variations pour cause d'améliorations techniques. Nous nous réservons le droit d'apporter des modifications sans préavis.

• SCHEMA DI FUNZIONAMENTO • OPERATIONAL DIAGRAM  
• BETRIEBSSCHEMA • SCHÉMA DE FONCTIONNEMENT

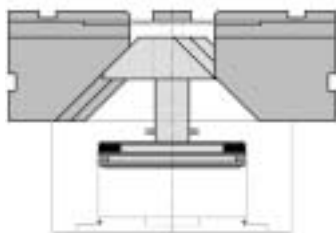

Aperto  
Open  
Geöffnet  
Ouvert

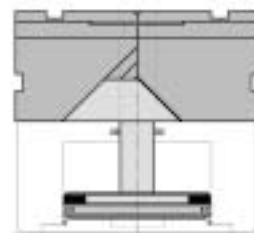

Chiuso  
Closed  
Geschlossen  
Fermé

OPE 205-3  
OPE 205-3 S

OPE 175-3  
OPE 175-3 S

OPE 125-3  
OPE 125-3 S

OPE 110-3  
OPE 110-3 S

OPE 105-3  
OPE 105-3 S

OPE 90-3  
OPE 90-3 S

OPE 80-3  
OPE 80-3 S

OPE 65-3  
OPE 65-3 S

OPE 60-3  
OPE 60-3 S



- **ORGANO DI PRESA A CORSA PARALLELA A TRE GRIFFE**
- **Three-jaw parallel gripper**
- **Drei-finger Parallelgreifer**
- **Pince de préhension à course parallèle, à trois griffes**

**DIAGRAMMA FORZA DI CHIUSURA**  
**CLAMPING FORCE DIAGRAM • DIAGRAM SCHLIEßKRAFT**  
**DIAGRAMME DE LA FORCE DE FERMETURE**

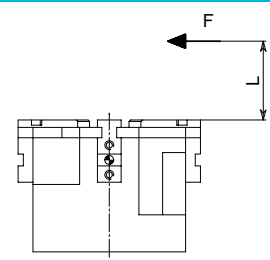
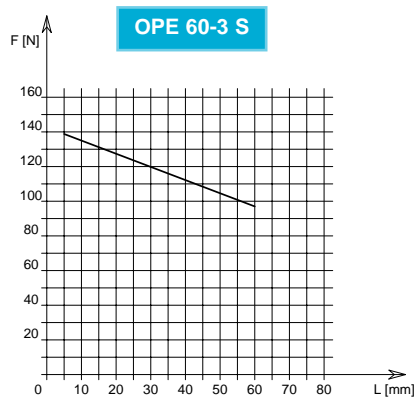
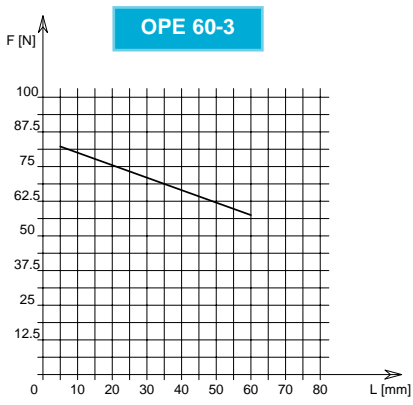

**P = 6 bar**

F = Forza di chiusura reale per griffa  
 L = Distanza di rilevamento

F = Reelle Schließkraft pro Greiffinger  
 L = Messungsabstand

F = True clamping force per jaw  
 L = Reading distance

F = Force de fermeture réelle par griffe  
 L = Distance de lecture

Valori nei dati tecnici rilevati alla distanza L = 10 mm • Technical specification values read at a distance L = 10 mm

• Werte der technischen Daten auf Distanz aufgenommen L = 10 mm • Valeurs des données techniques relevées à la distance L = 10 mm

**DATI TECNICI**

Corsa per griffa	.....5 mm	.....3 mm
Corsa pistone	.....6 mm	.....6 mm
Volume aria per doppia corsa	.....8 cm <sup>3</sup>	.....8 cm <sup>3</sup>
Forza teorica di chiusura per griffa a 6 bar	.....149 N	.....246 N
Forza reale di chiusura per griffa a 6 bar	.....80 N	.....135 N
Forza teorica di apertura per griffa a 6 bar	.....167 N	.....277 N
Forza reale di apertura per griffa a 6 bar	.....90 N	.....152 N
Pressione di esercizio	.....2-12 bar	.....2-12 bar
Ripetibilità	.....±0.05 mm	.....±0.05 mm
Peso	.....0.36 Kg	.....0.3 Kg
Temperatura di esercizio	.....-5-60 °C	.....-5-60 °C
Codice articolo	.....OE870PRE	.....OE670PRS

**OPE60-3 OPE60-3S**

**TECHNISCHE DATEN**

Hub pro Greiffinger	.....5 mm	.....3 mm
Kolbenhub	.....6 mm	.....6 mm
Luftvolumen pro Doppelhub	.....8 cm <sup>3</sup>	.....8 cm <sup>3</sup>
Theoretische Schließkraft pro Greiffinger 6 bar	.....149 N	.....246 N
Reelle Schließkraft pro Greiffinger 6 bar	.....80 N	.....135 N
Theoretische Öffnungskraft pro Greiffinger 6 bar	.....167 N	.....277 N
Reelle Öffnungskraft pro Greiffinger 6 bar	.....90 N	.....152 N
Betriebsdruck	.....2-12 bar	.....2-12 bar
Wiederholbarkeit	.....±0.05 mm	.....±0.05 mm
Gewicht	.....0.36 Kg	.....0.3 Kg
Betriebstemperatur	.....-5-60 °C	.....-5-60 °C
Artikelcode	.....OE870PRE	.....OE670PRS

**OPE60-3 OPE60-3S**

**SPECIFICATIONS**

Stroke per jaw	.....5 mm	.....3 mm
Piston stroke	.....6 mm	.....6 mm
Dual stroke air volume	.....8 cm <sup>3</sup>	.....8 cm <sup>3</sup>
Theoretical clamping force per jaw at 6 bar	.....149 N	.....246 N
Actual clamping force per jaw at 6 bar	.....80 N	.....135 N
Theoretical opening force per jaw at 6 bar	.....167 N	.....277 N
Actual opening force per jaw at 6 bar	.....90 N	.....152 N
Working pressure	.....2-12 bar	.....2-12 bar
Reproducibility	.....±0.05 mm	.....±0.05 mm
Weight	.....0.36 Kg	.....0.3 Kg
Working temperature	.....-5-60 °C	.....-5-60 °C
Article code	.....OE870PRE	.....OE670PRS

**OPE60-3 OPE60-3S**

**DONNÉES TECHNIQUES**

Course par griffe	.....5 mm	.....3 mm
Course piston	.....6 mm	.....6 mm
Volume d'air pour course double	.....8 cm <sup>3</sup>	.....8 cm <sup>3</sup>
Force théorique en fermeture par griffe à 6 bar	.....149 N	.....246 N
Force réelle en fermeture par griffe à 6 bar	.....80 N	.....135 N
Force théorique en ouverture par griffe à 6 bar	.....167 N	.....277 N
Force réelle en ouverture par griffe à 6 bar	.....90 N	.....152 N
Pression d'exercice	.....2-12 bar	.....2-12 bar
Répétibilité	.....±0.05 mm	.....±0.05 mm
Poids	.....0.36 Kg	.....0.3 Kg
Température d'exercice	.....-5-60 °C	.....-5-60 °C
Code article	.....OE870PRE	.....OE670PRS

**OPE60-3 OPE60-3S**

OPE 205-3  
OPE 205-3 S

OPE 175-3  
OPE 175-3 S

OPE 125-3  
OPE 125-3 S

OPE 110-3  
OPE 110-3 S

OPE 105-3  
OPE 105-3 S

OPE 90-3  
OPE 90-3 S

OPE 80-3  
OPE 80-3 S

OPE 65-3  
OPE 65-3 S

OPE 60-3  
OPE 60-3 S



- **ORGANO DI PRESA A CORSA PARALLELA A TRE GRIFFE**
- **Three-jaw parallel gripper**
- **Drei-finger Parallelgreifer**
- **Pince de préhension à course parallèle, à trois griffes**

• Disegno OPE 65-3 • Drawing OPE 65-3 • Zeichnung OPE 65-3 • Dessin OPE 65-3

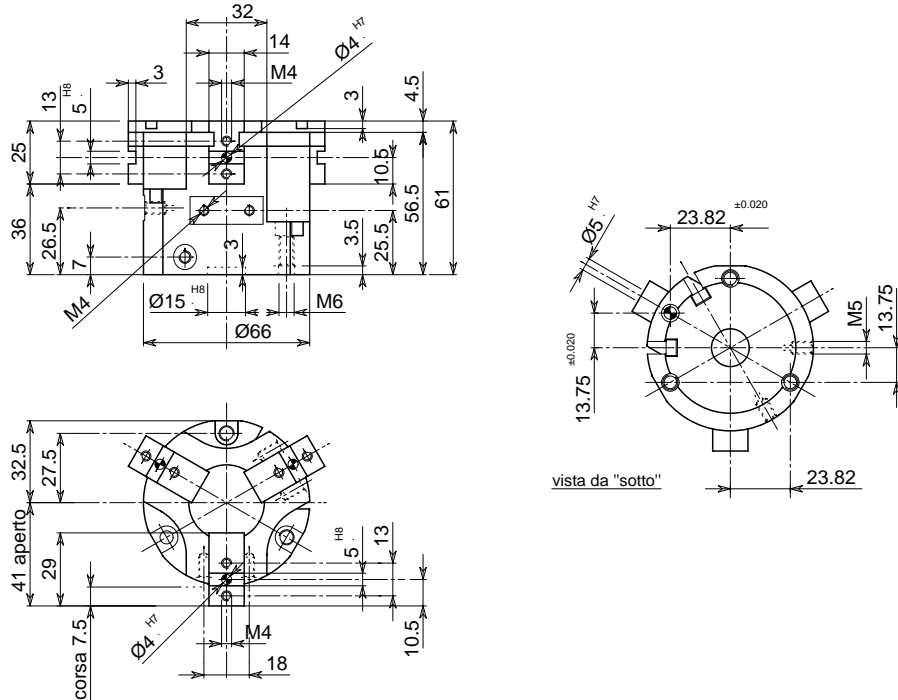

• Versione OPE 65-3 S • Version OPE 65-3 S • Ausführung OPE 65-3 S • Version OPE 65-3 S

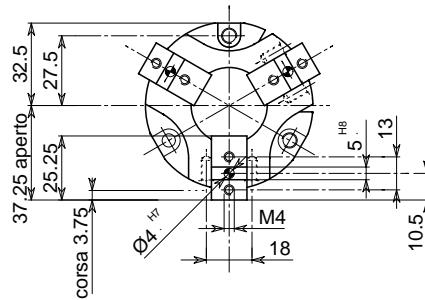

• Le dimensioni sono indicative e suscettibili di variazioni per migliorie tecniche. Ci riserviamo di apportare modifiche senza preavviso • All dimensions are indicative and subject to variation for technical upgrading. We reserve the right to make alterations without prior notification • Die Maßangaben sind indikativ und können sich bei technischen Verbesserung ändern. Wir behalten uns vor, ohne vorherige Benachrichtigung Änderungen vorzunehmen • Les dimensions sont fournies à titre indicatif, elles peuvent subir des variations pour cause d'améliorations techniques. Nous nous réservons le droit d'apporter des modifications sans préavis.

• SCHEMA DI FUNZIONAMENTO • OPERATIONAL DIAGRAM  
• BETRIEBSSCHEMA • SCHÉMA DE FONCTIONNEMENT

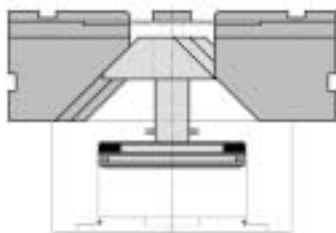

Aperto  
Open  
Geöffnet  
Ouvert

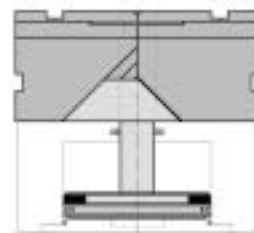

Chiuso  
Closed  
Geschlossen  
Fermé

OPE 205-3  
OPE 205-3 S

OPE 175-3  
OPE 175-3 S

OPE 125-3  
OPE 125-3 S

OPE 110-3  
OPE 110-3 S

OPE 105-3  
OPE 105-3 S

OPE 90-3  
OPE 90-3 S

OPE 80-3  
OPE 80-3 S

OPE 65-3  
OPE 65-3 S

OPE 60-3  
OPE 60-3 S



- **ORGANO DI PRESA A CORSA PARALLELA A TRE GRIFFE**
- **Three-jaw parallel gripper**
- **Drei-finger Parallelgreifer**
- **Pince de préhension à course parallèle, à trois griffes**

**DIAGRAMMA FORZA DI CHIUSURA**  
**CLAMPING FORCE DIAGRAM • DIAGRAM SCHLIEßKRAFT**  
**DIAGRAMME DE LA FORCE DE FERMETURE**

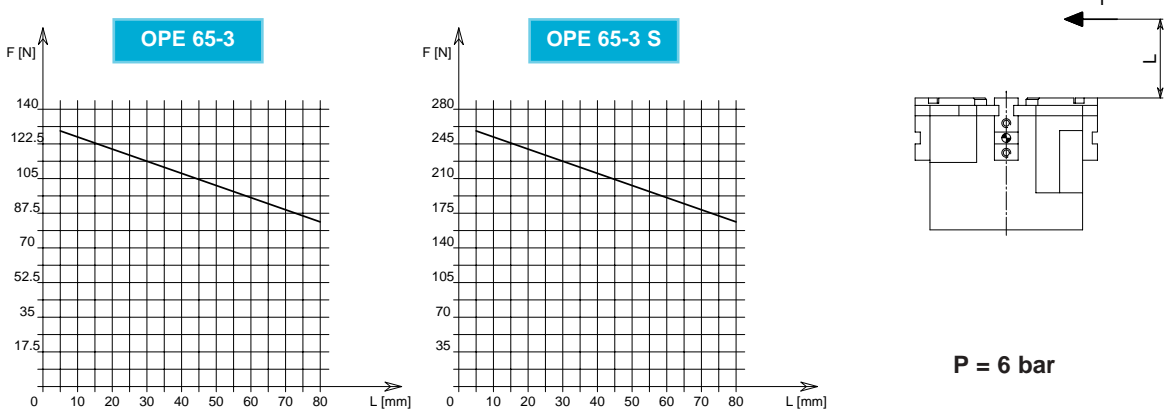

F = Forza di chiusura reale per griffa  
 L = Distanza di rilevamento

F = Reelle Schließkraft pro Greiffinger  
 L = Messungsabstand

F = True clamping force per jaw  
 L = Reading distance

F = Force de fermeture réelle par griffe  
 L = Distance de lecture

Valori nei dati tecnici rilevati alla distanza L = 10 mm • Technical specification values read at a distance L = 10 mm

• Werte der technischen Daten auf Distanz aufgenommen L = 10 mm • Valeurs des données techniques relevées à la distance L = 10 mm

**DATI TECNICI**

	<b>OPE65-3</b>	<b>OPE65-3S</b>
Corsa per griffa	7.5 mm	3.75 mm
Corsa pistone	7.5 mm	7.5 mm
Volume aria per doppia corsa	18 cm <sup>3</sup>	18 cm <sup>3</sup>
Forza teorica di chiusura per griffa a 6 bar	229 N	449 N
Forza reale di chiusura per griffa a 6 bar	126 N	247 N
Forza teorica di apertura per griffa a 6 bar	252 N	494 N
Forza reale di apertura per griffa a 6 bar	138 N	272 N
Pressione di esercizio	2-12 bar	2-12 bar
Ripetibilità	±0.05 mm	±0.05 mm
Peso	0.57 Kg	0.5 Kg
Temperatura di esercizio	-5-60 °C	-5-60 °C
Codice articolo	.0E871PBE	.0E671PBS

**SPECIFICATIONS**

	<b>OPE65-3</b>	<b>OPE65-3S</b>
Stroke per jaw	7.5 mm	3.75 mm
Piston stroke	7.5 mm	7.5 mm
Dual stroke air volume	18 cm <sup>3</sup>	18 cm <sup>3</sup>
Theoretical clamping force per jaw at 6 bar	229 N	449 N
Actual clamping force per jaw at 6 bar	126 N	247 N
Theoretical opening force per jaw at 6 bar	252 N	494 N
Actual opening force per jaw at 6 bar	138 N	272 N
Working pressure	2-12 bar	2-12 bar
Reproducibility	±0.05 mm	±0.05 mm
Weight	0.57 Kg	0.5 Kg
Working temperature	-5-60 °C	-5-60 °C
Article code	.0E871PBE	.0E671PBS

**TECHNISCHE DATEN**

	<b>OPE65-3</b>	<b>OPE65-3S</b>
Hub pro Greiffinger	7.5 mm	3.75 mm
Kolbenhub	7.5 mm	7.5 mm
Luftvolumen pro Doppelhub	18 cm <sup>3</sup>	18 cm <sup>3</sup>
Theoretische Schließkraft pro Greiffinger 6 bar	229 N	449 N
Reale Schließkraft pro Greiffinger 6 bar	126 N	247 N
Theoretische Öffnungskraft pro Greiffinger 6 bar	252 N	494 N
Reale Öffnungskraft pro Greiffinger 6 bar	138 N	272 N
Betriebsdruck	2-12 bar	2-12 bar
Wiederholbarkeit	±0.05 mm	±0.05 mm
Gewicht	0.57 Kg	0.5 Kg
Betriebstemperatur	-5-60 °C	-5-60 °C
Artikelcode	.0E871PBE	.0E671PBS

**DONNÉES TECHNIQUES**

	<b>OPE65-3</b>	<b>OPE65-3S</b>
Course par griffe	7.5 mm	3.75 mm
Course piston	7.5 mm	7.5 mm
Volume d'air pour course double	18 cm <sup>3</sup>	18 cm <sup>3</sup>
Force théorique en fermeture par griffe à 6 bar	229 N	449 N
Force réelle en fermeture par griffe à 6 bar	126 N	247 N
Force théorique en ouverture par griffe à 6 bar	252 N	494 N
Force réelle en ouverture par griffe à 6 bar	138 N	272 N
Pression d'exercice	2-12 bar	2-12 bar
Répétibilité	±0.05 mm	±0.05 mm
Poids	0.57 Kg	0.5 Kg
Température d'exercice	-5-60 °C	-5-60 °C
Code article	.0E871PBE	.0E671PBS

OPE 205-3  
OPE 205-3 S

OPE 175-3  
OPE 175-3 S

OPE 125-3  
OPE 125-3 S

OPE 110-3  
OPE 110-3 S

OPE 105-3  
OPE 105-3 S

OPE 90-3  
OPE 90-3 S

OPE 80-3  
OPE 80-3 S

OPE 65-3  
OPE 65-3 S

OPE 60-3  
OPE 60-3 S



• **ORGANO DI PRESA A CORSA PARALLELA A TRE GRIFFE**  
 • **Three-jaw parallel gripper**  
 • **Drei-finger Parallelgreifer**  
 • **Pince de préhension à course parallèle, à trois griffes**

• Disegno OPE 80-3 • Drawing OPE 80-3 • Zeichnung OPE 80-3 • Dessin OPE 80-3

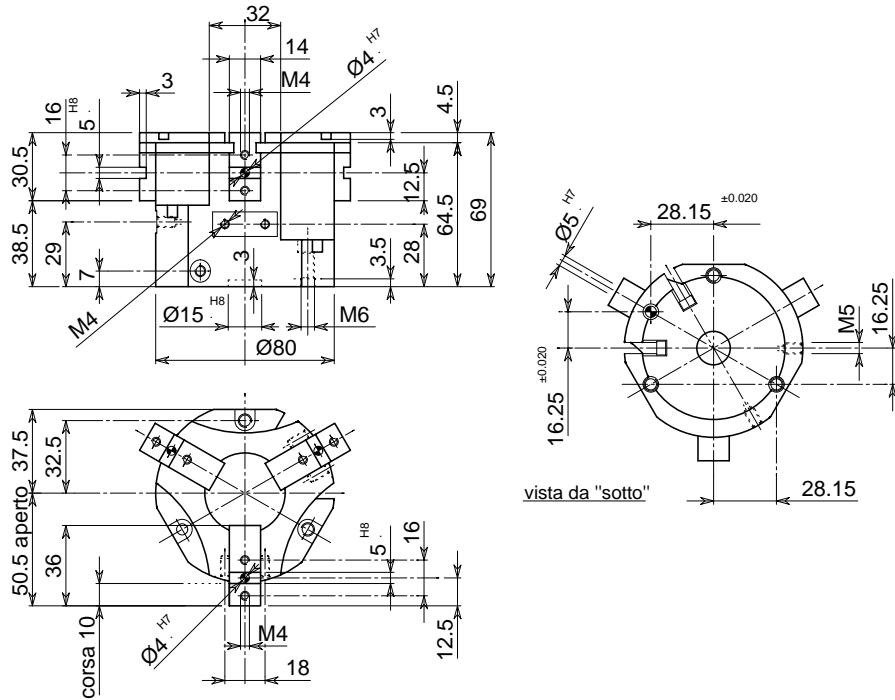

• Versione OPE 80-3 S • Version OPE 80-3 S • Ausführung OPE 80-3 S • Version OPE 80-3 S

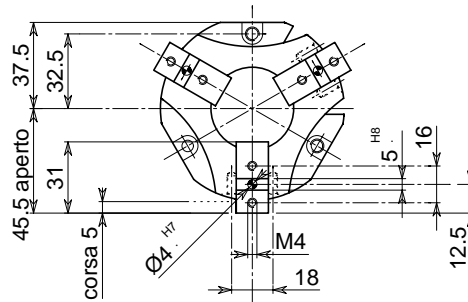

• Le dimensioni sono indicative e suscettibili di variazioni per migliorie tecniche. Ci riserviamo di apportare modifiche senza preavviso • All dimensions are indicative and subject to variation for technical upgrading. We reserve the right to make alterations without prior notification • Die Maßangaben sind indikativ und können sich bei technischen Verbesserung ändern. Wir behalten uns vor, ohne vorherige Benachrichtigung Änderungen vorzunehmen • Les dimensions sont fournies à titre indicatif, elles peuvent subir des variations pour cause d'améliorations techniques. Nous nous réservons le droit d'apporter des modifications sans préavis.

• **SCHEMA DI FUNZIONAMENTO • OPERATIONAL DIAGRAM**  
 • **BETRIEBSSCHEMA • SCHÉMA DE FONCTIONNEMENT**

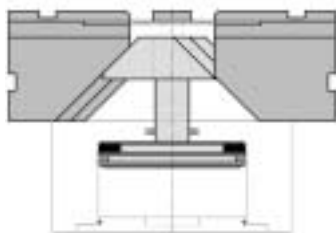

Aperto  
 Open  
 Geöffnet  
 Ouvert

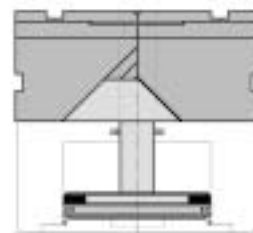

Chiuso  
 Closed  
 Geschlossen  
 Fermé

OPE 205-3  
 OPE 205-3 S

OPE 175-3  
 OPE 175-3 S

OPE 125-3  
 OPE 125-3 S

OPE 110-3  
 OPE 110-3 S

OPE 105-3  
 OPE 105-3 S

OPE 90-3  
 OPE 90-3 S

**OPE 80-3**  
**OPE 80-3 S**

OPE 65-3  
 OPE 65-3 S

OPE 60-3  
 OPE 60-3 S



- **ORGANO DI PRESA A CORSA PARALLELA A TRE GRIFFE**
- **Three-jaw parallel gripper**
- **Drei-finger Parallelgreifer**
- **Pince de préhension à course parallèle, à trois griffes**

**DIAGRAMMA FORZA DI CHIUSURA**  
**CLAMPING FORCE DIAGRAM • DIAGRAM SCHLIEßKRAFT**  
**DIAGRAMME DE LA FORCE DE FERMETURE**

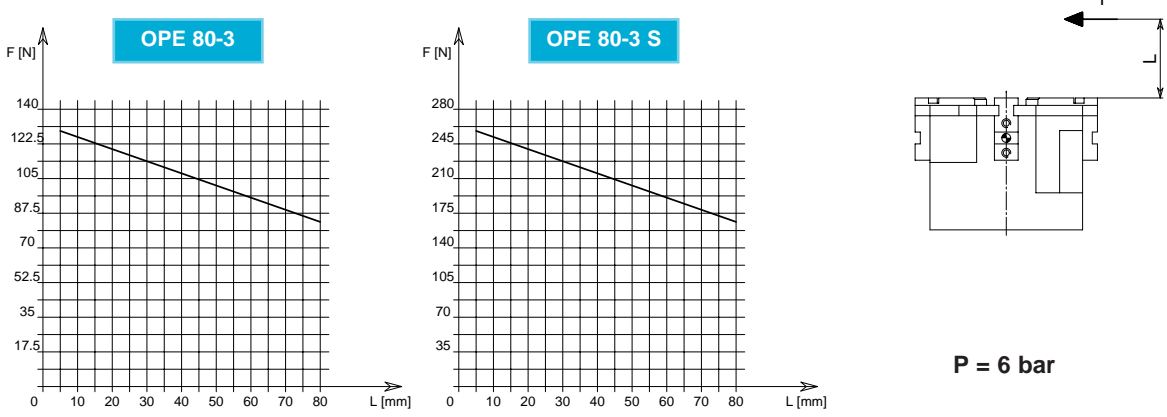

F = Forza di chiusura reale per griffa  
 L = Distanza di rilevamento

F = Reelle Schließkraft pro Greiffinger  
 L = Messungsabstand

F = True clamping force per jaw  
 L = Reading distance

F = Force de fermeture réelle par griffe  
 L = Distance de lecture

Valori nei dati tecnici rilevati alla distanza L = 10 mm • Technical specification values read at a distance L = 10 mm

• Werte der technischen Daten auf Distanz aufgenommen L = 10 mm • Valeurs des données techniques relevées à la distance L = 10 mm

**DATI TECNICI**

	<b>OPE80-3</b>	<b>OPE80-3S</b>
Corsa per griffa	10 mm	5 mm
Corsa pistone	10 mm	10 mm
Volume aria per doppia corsa	26 cm <sup>3</sup>	26 cm <sup>3</sup>
Forza teorica di chiusura per griffa a 6 bar	229 N	449 N
Forza reale di chiusura per griffa a 6 bar	126 N	247 N
Forza teorica di apertura per griffa a 6 bar	252 N	494 N
Forza reale di apertura per griffa a 6 bar	138 N	272 N
Pressione di esercizio	2-12 bar	2-12 bar
Ripetibilità	±0.05 mm	±0.05 mm
Peso	0.9 Kg	0.85 Kg
Temperatura di esercizio	-5-60 °C	-5-60 °C
Codice articolo	.OE872PCE	.OE672PCS

**SPECIFICATIONS**

	<b>OPE80-3</b>	<b>OPE80-3S</b>
Stroke per jaw	10 mm	5 mm
Piston stroke	10 mm	10 mm
Dual stroke air volume	26 cm <sup>3</sup>	26 cm <sup>3</sup>
Theoretical clamping force per jaw at 6 bar	229 N	449 N
Actual clamping force per jaw at 6 bar	126 N	247 N
Theoretical opening force per jaw at 6 bar	252 N	494 N
Actual opening force per jaw at 6 bar	138 N	272 N
Working pressure	2-12 bar	2-12 bar
Reproducibility	±0.05 mm	±0.05 mm
Weight	0.9 Kg	0.85 Kg
Working temperature	-5-60 °C	-5-60 °C
Article code	.OE872PCE	.OE672PCS

**TECHNISCHE DATEN**

	<b>OPE80-3</b>	<b>OPE80-3S</b>
Hub pro Greiffinger	10 mm	5 mm
Kolbenhub	10 mm	10 mm
Luftvolumen pro Doppelhub	26 cm <sup>3</sup>	26 cm <sup>3</sup>
Theoretische Schließkraft pro Greiffinger 6 bar	229 N	449 N
Reelle Schließkraft pro Greiffinger 6 bar	126 N	247 N
Theoretische Öffnungskraft pro Greiffinger 6 bar	252 N	494 N
Reelle Öffnungskraft pro Greiffinger 6 bar	138 N	272 N
Betriebsdruck	2-12 bar	2-12 bar
Wiederholbarkeit	±0.05 mm	±0.05 mm
Gewicht	0.9 Kg	0.85 Kg
Betriebstemperatur	-5-60 °C	-5-60 °C
Artikelcode	.OE872PCE	.OE672PCS

**DONNÉES TECHNIQUES**

	<b>OPE80-3</b>	<b>OPE80-3S</b>
Course par griffe	10 mm	5 mm
Course piston	10 mm	10 mm
Volume d'air pour course double	26 cm <sup>3</sup>	26 cm <sup>3</sup>
Force théorique en fermeture par griffe à 6 bar	229 N	449 N
Force réelle en fermeture par griffe à 6 bar	126 N	247 N
Force théorique en ouverture par griffe à 6 bar	252 N	494 N
Force réelle en ouverture par griffe à 6 bar	138 N	272 N
Pression d'exercice	2-12 bar	2-12 bar
Répétibilité	±0.05 mm	±0.05 mm
Poids	0.9 Kg	0.85 Kg
Température d'exercice	-5-60 °C	-5-60 °C
Code article	.OE872PCE	.OE672PCS

OPE 205-3  
OPE 205-3 S

OPE 175-3  
OPE 175-3 S

OPE 125-3  
OPE 125-3 S

OPE 110-3  
OPE 110-3 S

OPE 105-3  
OPE 105-3 S

OPE 90-3  
OPE 90-3 S

OPE 80-3  
OPE 80-3 S

OPE 65-3  
OPE 65-3 S

OPE 60-3  
OPE 60-3 S





- **ORGANO DI PRESA A CORSA PARALLELA A TRE GRIFFE**
- **Three-jaw parallel gripper**
- **Drei-finger Parallelgreifer**
- **Pince de préhension à course parallèle, à trois griffes**

**DIAGRAMMA FORZA DI CHIUSURA**  
**CLAMPING FORCE DIAGRAM • DIAGRAM SCHLIEßKRAFT**  
**DIAGRAMME DE LA FORCE DE FERMETURE**

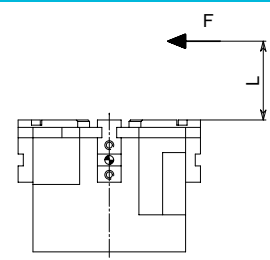
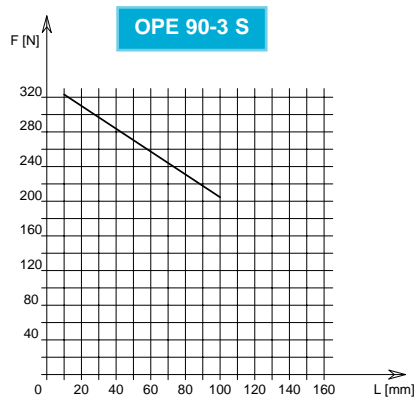
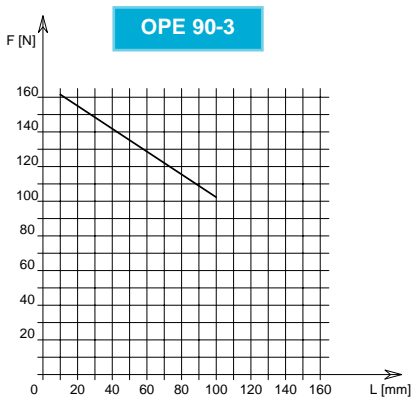

**P = 6 bar**

F = Forza di chiusura reale per griffa  
 L = Distanza di rilevamento

F = Reelle Schließkraft pro Greiffinger  
 L = Messungsabstand

F = True clamping force per jaw  
 L = Reading distance

F = Force de fermeture réelle par griffe  
 L = Distance de lecture

Valori nei dati tecnici rilevati alla distanza L = 20 mm • Technical specification values read at a distance L = 20 mm

• Werte der technischen Daten auf Distanz aufgenommen L = 20 mm • Valeurs des données techniques relevées à la distance L = 20 mm

**DATI TECNICI**

	<b>OPE90-3</b>	<b>OPE90-3S</b>
Corsa per griffa	12 mm	6 mm
Corsa pistone	12 mm	12 mm
Volume aria per doppia corsa	36.5 cm <sup>3</sup>	36.5 cm <sup>3</sup>
Forza teorica di chiusura per griffa a 6 bar	287 N	563 N
Forza reale di chiusura per griffa a 6 bar	155 N	310 N
Forza teorica di apertura per griffa a 6 bar	319 N	625 N
Forza reale di apertura per griffa a 6 bar	172 N	344 N
Pressione di esercizio	2-12 bar	2-12 bar
Ripetibilità	±0.05 mm	±0.05 mm
Peso	1.3 Kg	1.2 Kg
Temperatura di esercizio	-5-60 °C	-5-60 °C
Codice articolo	.OE873PDE	.OE673PDS

**SPECIFICATIONS**

	<b>OPE90-3</b>	<b>OPE90-3S</b>
Stroke per jaw	12 mm	6 mm
Piston stroke	12 mm	12 mm
Dual stroke air volume	36.5 cm <sup>3</sup>	36.5 cm <sup>3</sup>
Theoretical clamping force per jaw at 6 bar	287 N	563 N
Actual clamping force per jaw at 6 bar	155 N	310 N
Theoretical opening force per jaw at 6 bar	319 N	625 N
Actual opening force per jaw at 6 bar	172 N	344 N
Working pressure	2-12 bar	2-12 bar
Reproducibility	±0.05 mm	±0.05 mm
Weight	1.3 Kg	1.2 Kg
Working temperature	-5-60 °C	-5-60 °C
Article code	.OE873PDE	.OE673PDS

**TECHNISCHE DATEN**

	<b>OPE90-3</b>	<b>OPE90-3S</b>
Hub pro Greiffinger	12 mm	6 mm
Kolbenhub	12 mm	12 mm
Luftvolumen pro Doppelhub	36.5 cm <sup>3</sup>	36.5 cm <sup>3</sup>
Theoretische Schließkraft pro Greiffinger 6 bar	287 N	563 N
Reelle Schließkraft pro Greiffinger 6 bar	155 N	310 N
Theoretische Öffnungskraft pro Greiffinger 6 bar	319 N	625 N
Reelle Öffnungskraft pro Greiffinger 6 bar	172 N	344 N
Betriebsdruck	2-12 bar	2-12 bar
Wiederholbarkeit	±0.05 mm	±0.05 mm
Gewicht	1.3 Kg	1.2 Kg
Betriebstemperatur	-5-60 °C	-5-60 °C
Artikelcode	.OE873PDE	.OE673PDS

**DONNÉES TECHNIQUES**

	<b>OPE90-3</b>	<b>OPE90-3S</b>
Course par griffe	12 mm	6 mm
Course piston	12 mm	12 mm
Volume d'air pour course double	36.5 cm <sup>3</sup>	36.5 cm <sup>3</sup>
Force théorique en fermeture par griffe à 6 bar	287 N	563 N
Force réelle en fermeture par griffe à 6 bar	155 N	310 N
Force théorique en ouverture par griffe à 6 bar	319 N	625 N
Force réelle en ouverture par griffe à 6 bar	172 N	344 N
Pression d'exercice	2-12 bar	2-12 bar
Répétibilité	±0.05 mm	±0.05 mm
Poids	1.3 Kg	1.2 Kg
Température d'exercice	-5-60 °C	-5-60 °C
Code article	.OE873PDE	.OE673PDS

OPE 205-3  
OPE 205-3 S

OPE 175-3  
OPE 175-3 S

OPE 125-3  
OPE 125-3 S

OPE 110-3  
OPE 110-3 S

OPE 105-3  
OPE 105-3 S

OPE 90-3  
OPE 90-3 S

OPE 80-3  
OPE 80-3 S

OPE 65-3  
OPE 65-3 S

OPE 60-3  
OPE 60-3 S



- **ORGANO DI PRESA A CORSA PARALLELA A TRE GRIFFE**
- **Three-jaw parallel gripper**
- **Drei-finger Parallelgreifer**
- **Pince de préhension à course parallèle, à trois griffes**

• Disegno OPE 105-3 • Drawing OPE 105-3 • Zeichnung OPE 105-3 • Dessin OPE 105-3

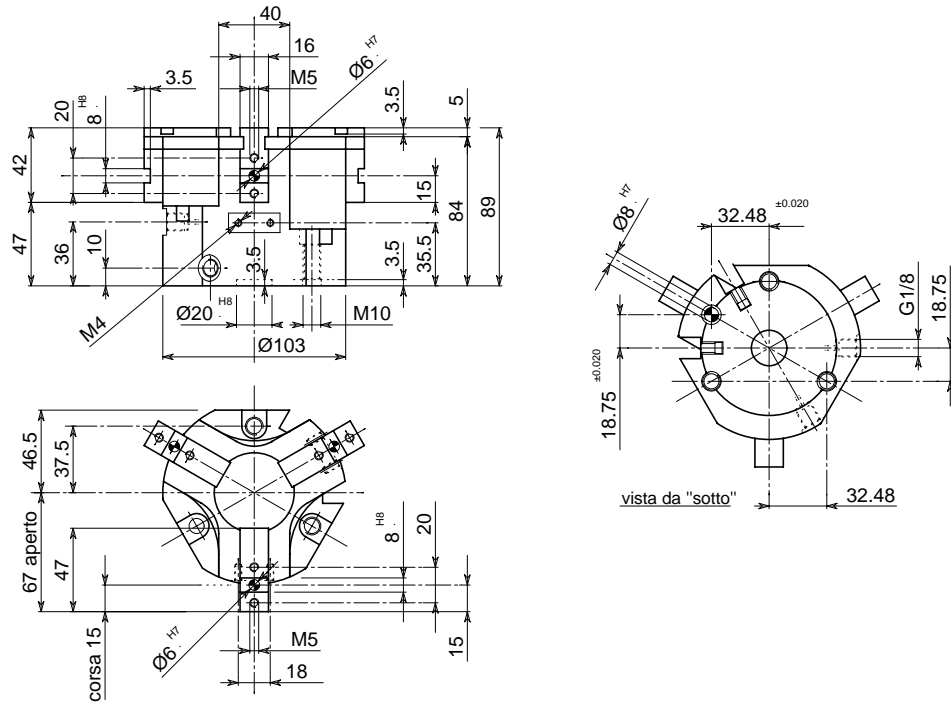

• Versione OPE 105-3 S • Version OPE 105-3 S • Ausführung OPE 105-3 S • Version OPE 105-3 S

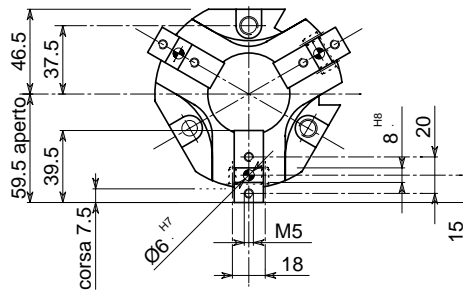

• Le dimensioni sono indicative e suscettibili di variazioni per migliorie tecniche. Ci riserviamo di apportare modifiche senza preavviso • All dimensions are indicative and subject to variation for technical upgrading. We reserve the right to make alterations without prior notification • Die Maßangaben sind indikativ und können sich bei technischen Verbesserung ändern. Wir behalten uns vor, ohne vorherige Benachrichtigung Änderungen vorzunehmen • Les dimensions sont fournies à titre indicatif, elles peuvent subir des variations pour cause d'améliorations techniques. Nous nous réservons le droit d'apporter des modifications sans préavis.

- **SCHEMA DI FUNZIONAMENTO • OPERATIONAL DIAGRAM**
- **BETRIEBSSCHEMA • SCHÉMA DE FONCTIONNEMENT**

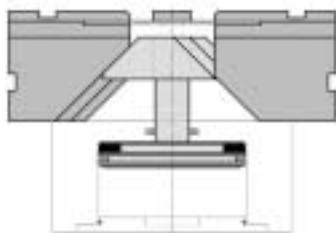

Aperto  
Open  
Geöffnet  
Ouvert

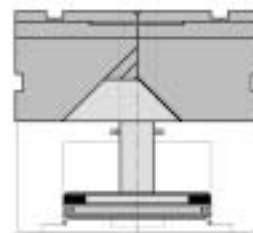

Chiuso  
Closed  
Geschlossen  
Fermé

OPE 205-3  
OPE 205-3 S

OPE 175-3  
OPE 175-3 S

OPE 125-3  
OPE 125-3 S

OPE 110-3  
OPE 110-3 S

OPE 105-3  
OPE 105-3 S

OPE 90-3  
OPE 90-3 S

OPE 80-3  
OPE 80-3 S

OPE 65-3  
OPE 65-3 S

OPE 60-3  
OPE 60-3 S



**• ORGANO DI PRESA A CORSA PARALLELA A TRE GRIFFE**  
**• Three-jaw parallel gripper**  
**• Drei-finger Parallelgreifer**  
**• Pince de préhension à course parallèle, à trois griffes**

**DIAGRAMMA FORZA DI CHIUSURA**  
**CLAMPING FORCE DIAGRAM • DIAGRAM SCHLIEßKRAFT**  
**DIAGRAMME DE LA FORCE DE FERMETURE**

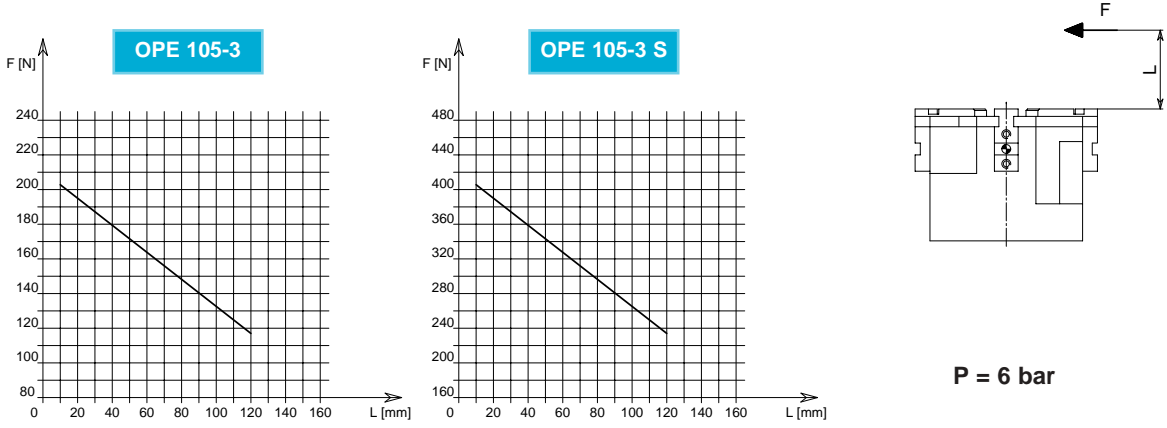

**F = Forza di chiusura reale per griffa**  
**L = Distanza di rilevamento**  
**F = True clamping force per jaw**  
**L = Reading distance**

**F = Reelle Schließkraft pro Greiffinger**  
**L = Messungsabstand**  
**F = Force de fermeture réelle par griffe**  
**L = Distance de lecture**

Valori nei dati tecnici rilevati alla distanza L = 20 mm • Technical specification values read at a distance L = 20 mm  
 • Werte der technischen Daten auf Distanz aufgenommen L = 20 mm • Valeurs des données techniques relevées à la distance L = 20 mm

DATI TECNICI	OPE105-3	OPE105-3S
Corsa per griffa	15 mm	7.5 mm
Corsa pistone	15 mm	15 mm
Volume aria per doppia corsa	.57 cm <sup>3</sup>	.57 cm <sup>3</sup>
Forza teorica di chiusura per griffa a 6 bar	.361 N	.710 N
Forza reale di chiusura per griffa a 6 bar	.195 N	.390 N
Forza teorica di apertura per griffa a 6 bar	.392 N	.771 N
Forza reale di apertura per griffa a 6 bar	.211 N	.422 N
Pressione di esercizio	.2-12 bar	.2-12 bar
Ripetibilità	±0.05 mm	±0.05 mm
Peso	2.1 Kg	1.85 Kg
Temperatura di esercizio	.5-60 °C	.5-60 °C
Codice articolo	.OE874PEE	.OE674PES

SPECIFICATIONS	OPE105-3	OPE105-3S
Stroke per jaw	15 mm	7.5 mm
Piston stroke	15 mm	15 mm
Dual stroke air volume	.57 cm <sup>3</sup>	.57 cm <sup>3</sup>
Theoretical clamping force per jaw at 6 bar	.361 N	.710 N
Actual clamping force per jaw at 6 bar	.195 N	.390 N
Theoretical opening force per jaw at 6 bar	.392 N	.771 N
Actual opening force per jaw at 6 bar	.211 N	.422 N
Working pressure	.2-12 bar	.2-12 bar
Reproducibility	±0.05 mm	±0.05 mm
Weight	2.1 Kg	1.85 Kg
Working temperature	.5-60 °C	.5-60 °C
Article code	.OE874PEE	.OE674PES

TECHNISCHE DATEN	OPE105-3	OPE105-3S
Hub pro Greiffinger	15 mm	7.5 mm
Kolbenhub	15 mm	15 mm
Luftvolumen pro Doppelhub	.57 cm <sup>3</sup>	.57 cm <sup>3</sup>
Theoretische Schließkraft pro Greiffinger 6 bar	.361 N	.710 N
Reelle Schließkraft pro Greiffinger 6 bar	.195 N	.390 N
Theoretische Öffnungskraft pro Greiffinger 6 bar	.392 N	.771 N
Reelle Öffnungskraft pro Greiffinger 6 bar	.211 N	.422 N
Betriebsdruck	.2-12 bar	.2-12 bar
Wiederholbarkeit	±0.05 mm	±0.05 mm
Gewicht	2.1 Kg	1.85 Kg
Betriebstemperatur	.5-60 °C	.5-60 °C
Artikelcode	.OE874PEE	.OE674PES

DONNÉES TECHNIQUES	OPE105-3	OPE105-3S
Course par griffe	15 mm	7.5 mm
Course piston	15 mm	15 mm
Volume d'air pour course double	.57 cm <sup>3</sup>	.57 cm <sup>3</sup>
Force théorique en fermeture par griffe à 6 bar	.361 N	.710 N
Force réelle en fermeture par griffe à 6 bar	.195 N	.390 N
Force théorique en ouverture par griffe à 6 bar	.392 N	.771 N
Force réelle en ouverture par griffe à 6 bar	.211 N	.422 N
Pression d'exercice	.2-12 bar	.2-12 bar
Réputibilité	±0.05 mm	±0.05 mm
Poids	2.1 Kg	1.85 Kg
Température d'exercice	.5-60 °C	.5-60 °C
Code article	.OE874PEE	.OE674PES

- OPE 205-3  
OPE 205-3 S
- OPE 175-3  
OPE 175-3 S
- OPE 125-3  
OPE 125-3 S
- OPE 110-3  
OPE 110-3 S
- OPE 105-3  
OPE 105-3 S
- OPE 90-3  
OPE 90-3 S
- OPE 80-3  
OPE 80-3 S
- OPE 65-3  
OPE 65-3 S
- OPE 60-3  
OPE 60-3 S





- **ORGANO DI PRESA A CORSA PARALLELA A TRE GRIFFE**
- **Three-jaw parallel gripper**
- **Drei-finger Parallelgreifer**
- **Pince de préhension à course parallèle, à trois griffes**

**DIAGRAMMA FORZA DI CHIUSURA**  
**CLAMPING FORCE DIAGRAM • DIAGRAM SCHLIEßKRAFT**  
**DIAGRAMME DE LA FORCE DE FERMETURE**

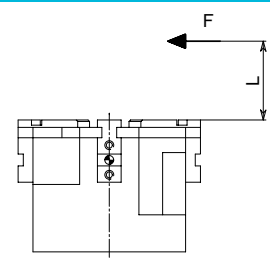
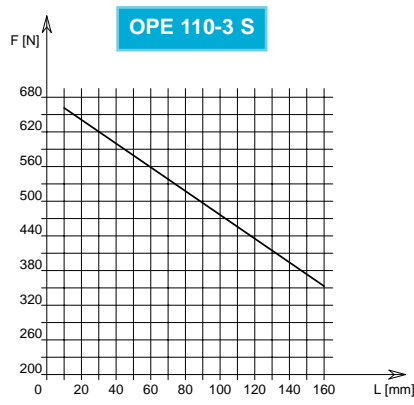
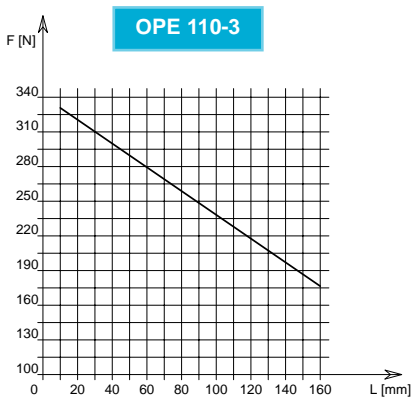

**P = 6 bar**

F = Forza di chiusura reale per griffa  
 L = Distanza di rilevamento

F = Reelle Schließkraft pro Greiffinger  
 L = Messungsabstand

F = True clamping force per jaw  
 L = Reading distance

F = Force de fermeture réelle par griffe  
 L = Distance de lecture

Valori nei dati tecnici rilevati alla distanza L = 20 mm • Technical specification values read at a distance L = 20 mm

• Werte der technischen Daten auf Distanz aufgenommen L = 20 mm • Valeurs des données techniques relevées à la distance L = 20 mm

**DATI TECNICI**

	OPE110-3	OPE110-3S
Corsa per griffa	10 mm	5 mm
Corsa pistone	10 mm	10 mm
Volume aria per doppia corsa	60.5 cm <sup>3</sup>	60.5 cm <sup>3</sup>
Forza teorica di chiusura per griffa a 6 bar	583 N	1144 N
Forza reale di chiusura per griffa a 6 bar	320 N	629 N
Forza teorica di apertura per griffa a 6 bar	623 N	1222 N
Forza reale di apertura per griffa a 6 bar	342 N	671 N
Pressione di esercizio	2-12 bar	2-12 bar
Ripetibilità	±0.05 mm	±0.05 mm
Peso	2.35 Kg	2.2 Kg
Temperatura di esercizio	-5-60 °C	-5-60 °C
Codice articolo	.OE879PLE	.OE679PLS

**SPECIFICATIONS**

	OPE110-3	OPE110-3S
Stroke per jaw	10 mm	5 mm
Piston stroke	10 mm	10 mm
Dual stroke air volume	60.5 cm <sup>3</sup>	60.5 cm <sup>3</sup>
Theoretical clamping force per jaw at 6 bar	583 N	1144 N
Actual clamping force per jaw at 6 bar	320 N	629 N
Theoretical opening force per jaw at 6 bar	623 N	1222 N
Actual opening force per jaw at 6 bar	342 N	671 N
Working pressure	2-12 bar	2-12 bar
Reproducibility	±0.05 mm	±0.05 mm
Weight	2.35 Kg	2.2 Kg
Working temperature	-5-60 °C	-5-60 °C
Article code	.OE879PLE	.OE679PLS

**TECHNISCHE DATEN**

	OPE110-3	OPE110-3S
Hub pro Greiffinger	10 mm	5 mm
Kolbenhub	10 mm	10 mm
Luftvolumen pro Doppelhub	60.5 cm <sup>3</sup>	60.5 cm <sup>3</sup>
Theoretische Schließkraft pro Greiffinger 6 bar	583 N	1144 N
Reelle Schließkraft pro Greiffinger 6 bar	320 N	629 N
Theoretische Öffnungskraft pro Greiffinger 6 bar	623 N	1222 N
Reelle Öffnungskraft pro Greiffinger 6 bar	342 N	671 N
Betriebsdruck	2-12 bar	2-12 bar
Wiederholbarkeit	±0.05 mm	±0.05 mm
Gewicht	2.35 Kg	2.2 Kg
Betriebstemperatur	-5-60 °C	-5-60 °C
Artikelcode	.OE879PLE	.OE679PLS

**DONNÉES TECHNIQUES**

	OPE110-3	OPE110-3S
Course par griffe	10 mm	5 mm
Course piston	10 mm	10 mm
Volume d'air pour course double	60.5 cm <sup>3</sup>	60.5 cm <sup>3</sup>
Force théorique en fermeture par griffe à 6 bar	583 N	1144 N
Force réelle en fermeture par griffe à 6 bar	320 N	629 N
Force théorique en ouverture par griffe à 6 bar	623 N	1222 N
Force réelle en ouverture par griffe à 6 bar	342 N	671 N
Pression d'exercice	2-12 bar	2-12 bar
Répétibilité	±0.05 mm	±0.05 mm
Poids	2.35 Kg	2.2 Kg
Température d'exercice	-5-60 °C	-5-60 °C
Code article	.OE879PLE	.OE679PLS

OPE 205-3  
OPE 205-3 S

OPE 175-3  
OPE 175-3 S

OPE 125-3  
OPE 125-3 S

OPE 110-3  
OPE 110-3 S

OPE 105-3  
OPE 105-3 S

OPE 90-3  
OPE 90-3 S

OPE 80-3  
OPE 80-3 S

OPE 65-3  
OPE 65-3 S

OPE 60-3  
OPE 60-3 S



- **ORGANO DI PRESA A CORSA PARALLELA A TRE GRIFFE**
- **Three-jaw parallel gripper**
- **Drei-finger Parallelgreifer**
- **Pince de préhension à course parallèle, à trois griffes**

• Disegno OPE 125-3 • Drawing OPE 125-3 • Zeichnung OPE 125-3 • Dessin OPE 125-3

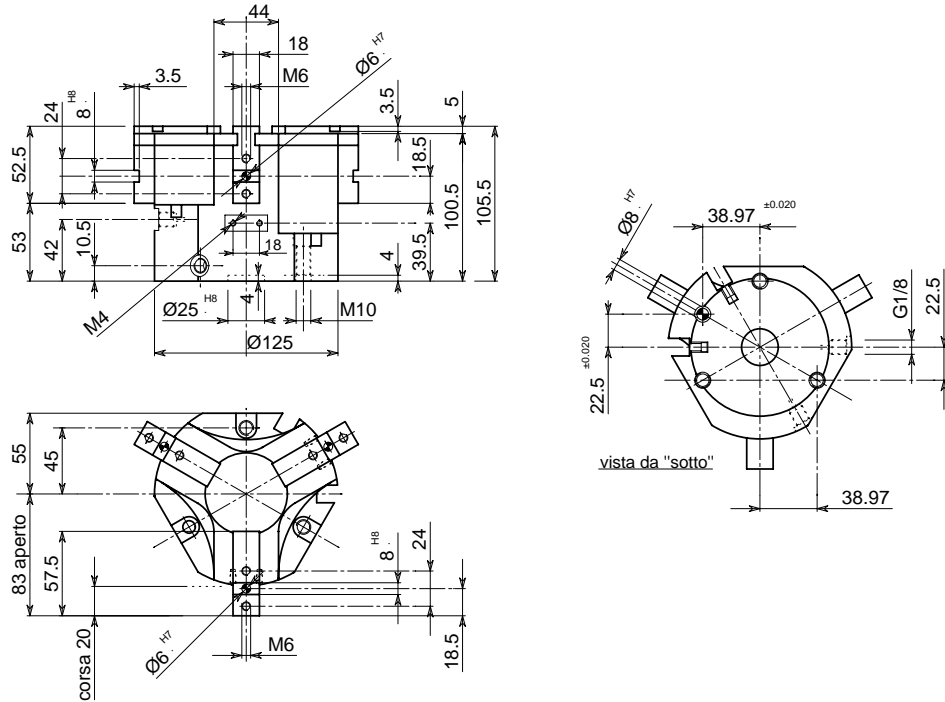

• Versione OPE 125-3 S • Version OPE 125-3 S • Ausführung OPE 125-3 S • Version OPE 125-3 S

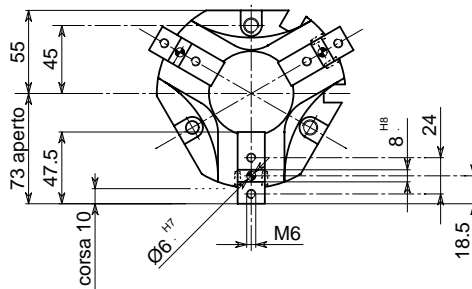

• Le dimensioni sono indicative e suscettibili di variazioni per migliorie tecniche. Ci riserviamo di apportare modifiche senza preavviso • All dimensions are indicative and subject to variation for technical upgrading. We reserve the right to make alterations without prior notification • Die Maßangaben sind indikativ und können sich bei technischen Verbesserung ändern. Wir behalten uns vor, ohne vorherige Benachrichtigung Änderungen vorzunehmen • Les dimensions sont fournies à titre indicatif, elles peuvent subir des variations pour cause d'améliorations techniques. Nous nous réservons le droit d'apporter des modifications sans préavis.

• SCHEMA DI FUNZIONAMENTO • OPERATIONAL DIAGRAM  
• BETRIEBSSCHEMA • SCHÉMA DE FONCTIONNEMENT

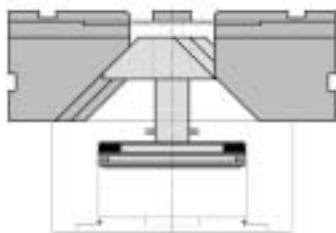

Aperto  
Open  
Geöffnet  
Ouvert

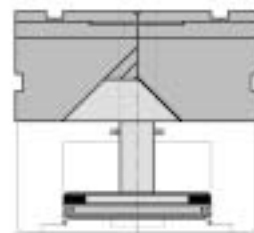

Chiuso  
Closed  
Geschlossen  
Fermé



- **ORGANO DI PRESA A CORSA PARALLELA A TRE GRIFFE**
- **Three-jaw parallel gripper**
- **Drei-finger Parallelgreifer**
- **Pince de préhension à course parallèle, à trois griffes**

**DIAGRAMMA FORZA DI CHIUSURA**  
**CLAMPING FORCE DIAGRAM • DIAGRAM SCHLIEßKRAFT**  
**DIAGRAMME DE LA FORCE DE FERMETURE**

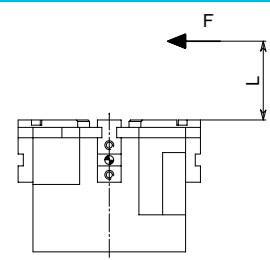
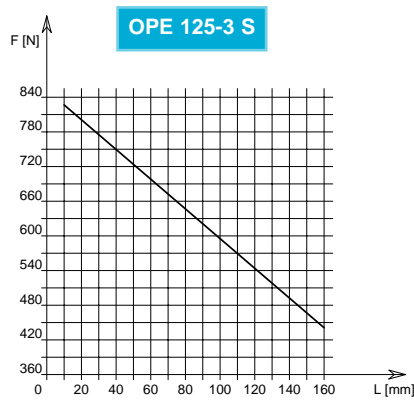
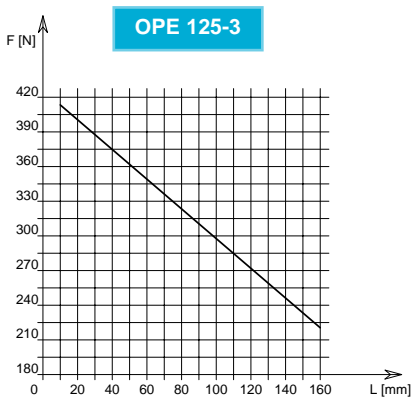

**P = 6 bar**

F = Forza di chiusura reale per griffa  
 L = Distanza di rilevamento

F = Reelle Schließkraft pro Greiffinger  
 L = Messungsabstand

F = True clamping force per jaw  
 L = Reading distance

F = Force de fermeture réelle par griffe  
 L = Distance de lecture

Valori nei dati tecnici rilevati alla distanza L = 20 mm • Technical specification values read at a distance L = 20 mm

• Werte der technischen Daten auf Distanz aufgenommen L = 20 mm • Valeurs des données techniques relevées à la distance L = 20 mm

**DATI TECNICI**

	OPE125-3	OPE125-3S
Corsa per griffa	.20 mm	.3 mm
Corsa pistone	.20 mm	.20 mm
Volume aria per doppia corsa	.150 cm <sup>3</sup>	.150 cm <sup>3</sup>
Forza teorica di chiusura per griffa a 6 bar	.729 N	.1431 N
Forza reale di chiusura per griffa a 6 bar	.400 N	.787 N
Forza teorica di apertura per griffa a 6 bar	.769 N	.1434 N
Forza reale di apertura per griffa a 6 bar	.422 N	.830 N
Pressione di esercizio	.2-12 bar	.2-12 bar
Ripetibilità	±0.05 mm	±0.05 mm
Peso	.3.15 Kg	.2.95 Kg
Temperatura di esercizio	.5-60 °C	.5-60 °C
Codice articolo	.0E875PFE	.0E675PFS

**SPECIFICATIONS**

	OPE125-3	OPE125-3S
Stroke per jaw	.20 mm	.3 mm
Piston stroke	.20 mm	.20 mm
Dual stroke air volume	.150 cm <sup>3</sup>	.150 cm <sup>3</sup>
Theoretical clamping force per jaw at 6 bar	.729 N	.1431 N
Actual clamping force per jaw at 6 bar	.400 N	.787 N
Theoretical opening force per jaw at 6 bar	.769 N	.1434 N
Actual opening force per jaw at 6 bar	.422 N	.830 N
Working pressure	.2-12 bar	.2-12 bar
Reproducibility	±0.05 mm	±0.05 mm
Weight	.3.15 Kg	.2.95 Kg
Working temperature	.5-60 °C	.5-60 °C
Article code	.0E875PFE	.0E675PFS

**TECHNISCHE DATEN**

	OPE125-3	OPE125-3S
Hub pro Greiffinger	.20 mm	.3 mm
Kolbenhub	.20 mm	.20 mm
Luftvolumen pro Doppelhub	.150 cm <sup>3</sup>	.150 cm <sup>3</sup>
Theoretische Schließkraft pro Greiffinger 6 bar	.729 N	.1431 N
Reale Schließkraft pro Greiffinger 6 bar	.400 N	.787 N
Theoretische Öffnungskraft pro Greiffinger 6 bar	.769 N	.1434 N
Reale Öffnungskraft pro Greiffinger 6 bar	.422 N	.830 N
Betriebsdruck	.2-12 bar	.2-12 bar
Wiederholbarkeit	±0.05 mm	±0.05 mm
Gewicht	.3.15 Kg	.2.95 Kg
Betriebstemperatur	.5-60 °C	.5-60 °C
Artikelcode	.0E875PFE	.0E675PFS

**DONNÉES TECHNIQUES**

	OPE125-3	OPE125-3S
Course par griffe	.20 mm	.3 mm
Course piston	.20 mm	.20 mm
Volume d'air pour course double	.150 cm <sup>3</sup>	.150 cm <sup>3</sup>
Force théorique en fermeture par griffe à 6 bar	.729 N	.1431 N
Force réelle en fermeture par griffe à 6 bar	.400 N	.787 N
Force théorique en ouverture par griffe à 6 bar	.769 N	.1434 N
Force réelle en ouverture par griffe à 6 bar	.422 N	.830 N
Pression d'exercice	.2-12 bar	.2-12 bar
Répétibilité	±0.05 mm	±0.05 mm
Poids	.3.15 Kg	.2.95 Kg
Température d'exercice	.5-60 °C	.5-60 °C
Code article	.0E875PFE	.0E675PFS

OPE 205-3  
OPE 205-3 S

OPE 175-3  
OPE 175-3 S

OPE 125-3  
OPE 125-3 S

OPE 110-3  
OPE 110-3 S

OPE 105-3  
OPE 105-3 S

OPE 90-3  
OPE 90-3 S

OPE 80-3  
OPE 80-3 S

OPE 65-3  
OPE 65-3 S

OPE 60-3  
OPE 60-3 S



• **ORGANO DI PRESA A CORSA PARALLELA A TRE GRIFFE**  
 • **Three-jaw parallel gripper**  
 • **Drei-finger Parallelgreifer**  
 • **Pince de préhension à course parallèle, à trois griffes**

• Disegno OPE 175-3 • Drawing OPE 175-3 • Zeichnung OPE 175-3 • Dessin OPE 175-3

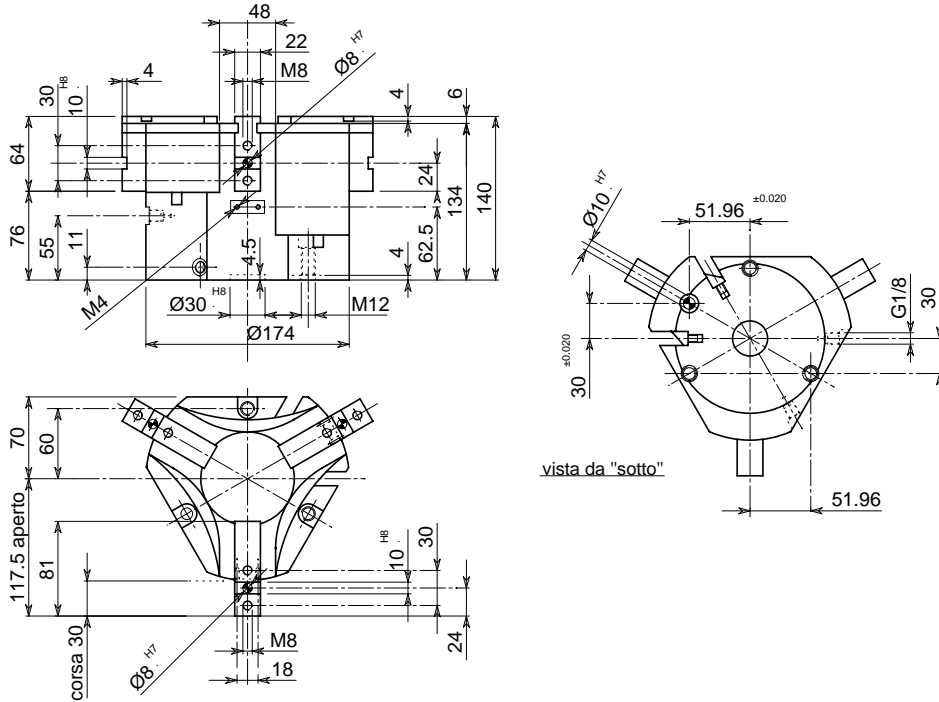

• Versione OPE 175-3 S • Version OPE 175-3 S • Ausführung OPE 175-3 S • Version OPE 175-3 S

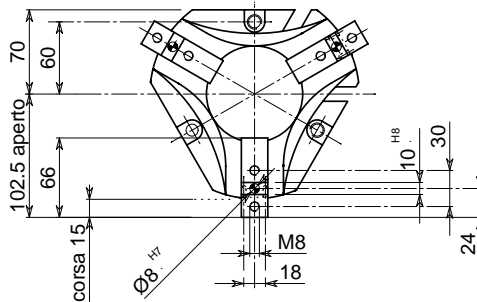

• Le dimensioni sono indicative e suscettibili di variazioni per migliorie tecniche. Ci riserviamo di apportare modifiche senza preavviso • All dimensions are indicative and subject to variation for technical upgrading. We reserve the right to make alterations without prior notification • Die Maßangaben sind indikativ und können sich bei technischen Verbesserungen ändern. Wir behalten uns vor, ohne vorherige Benachrichtigung Änderungen vorzunehmen • Les dimensions sont fournies à titre indicatif, elles peuvent subir des variations pour cause d'améliorations techniques. Nous nous réservons le droit d'apporter des modifications sans préavis.

• **SCHEMA DI FUNZIONAMENTO • OPERATIONAL DIAGRAM**  
 • **BETRIEBSSCHEMA • SCHÉMA DE FONCTIONNEMENT**

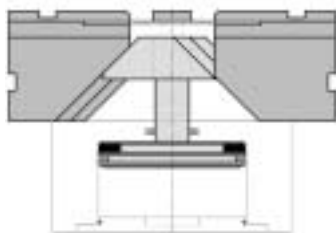

Aperto  
 Open  
 Geöffnet  
 Ouvert

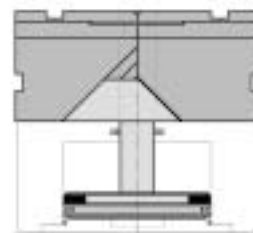

Chiuso  
 Closed  
 Geschlossen  
 Fermé

OPE 205-3  
 OPE 205-3 S

OPE 175-3  
 OPE 175-3 S

OPE 125-3  
 OPE 125-3 S

OPE 110-3  
 OPE 110-3 S

OPE 105-3  
 OPE 105-3 S

OPE 90-3  
 OPE 90-3 S

OPE 80-3  
 OPE 80-3 S

OPE 65-3  
 OPE 65-3 S

OPE 60-3  
 OPE 60-3 S



- **ORGANO DI PRESA A CORSA PARALLELA A TRE GRIFFE**
- **Three-jaw parallel gripper**
- **Drei-finger Parallelgreifer**
- **Pince de préhension à course parallèle, à trois griffes**

**DIAGRAMMA FORZA DI CHIUSURA**  
**CLAMPING FORCE DIAGRAM • DIAGRAM SCHLIEßKRAFT**  
**DIAGRAMME DE LA FORCE DE FERMETURE**

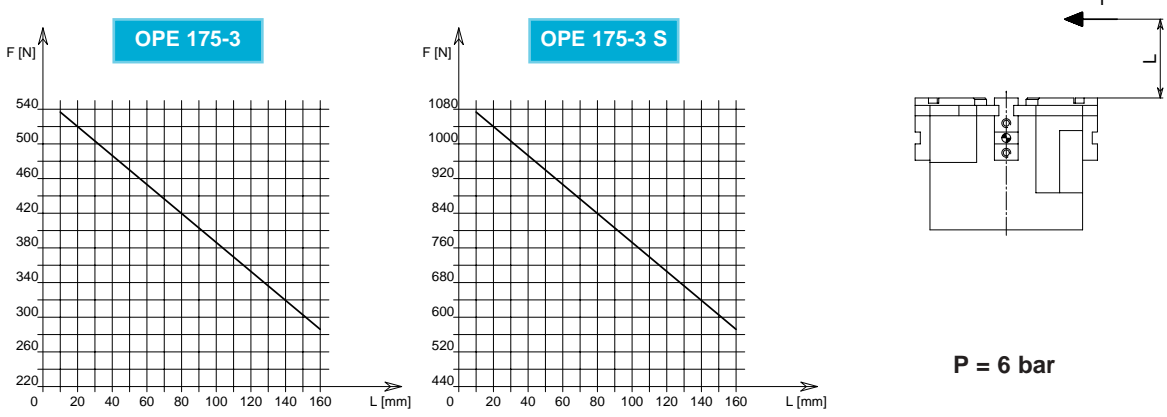

F = Forza di chiusura reale per griffa  
 L = Distanza di rilevamento

F = Reelle Schließkraft pro Greiffinger  
 L = Messungsabstand

F = True clamping force per jaw  
 L = Reading distance

F = Force de fermeture réelle par griffe  
 L = Distance de lecture

Valori nei dati tecnici rilevati alla distanza L = 20 mm • Technical specification values read at a distance L = 20 mm

• Werte der technischen Daten auf Distanz aufgenommen L = 20 mm • Valeurs des données techniques relevées à la distance L = 20 mm

<b>DATI TECNICI</b>	<b>OPE175-3</b>	<b>OPE175-3S</b>
Corsa per griffa	.30 mm	.15 mm
Corsa pistone	.30 mm	.30 mm
Volume aria per doppia corsa	.293 cm <sup>3</sup>	.293 cm <sup>3</sup>
Forza teorica di chiusura per griffa a 6 bar	.942 N	.1849 N
Forza reale di chiusura per griffa a 6 bar	.520 N	.1047 N
Forza teorica di apertura per griffa a 6 bar	.1005 N	.1973 N
Forza reale di apertura per griffa a 6 bar	.555 N	.1089 N
Pressione di esercizio	.2-12 bar	.2-12 bar
Ripetibilità	±0.05 mm	±0.05 mm
Peso	.6.5 Kg	.6 Kg
Temperatura di esercizio	.5-60 °C	.5-60 °C
Codice articolo	.0E876PGE	.0E676PGS

<b>TECHNISCHE DATEN</b>	<b>OPE175-3</b>	<b>OPE175-3S</b>
Hub pro Greiffinger	.30 mm	.15 mm
Kolbenhub	.30 mm	.30 mm
Luftvolumen pro Doppelhub	.293 cm <sup>3</sup>	.293 cm <sup>3</sup>
Theoretische Schließkraft pro Greiffinger 6 bar	.942 N	.1849 N
Reelle Schließkraft pro Greiffinger 6 bar	.520 N	.1047 N
Theoretische Öffnungskraft pro Greiffinger 6 bar	1005 N	.1973 N
Reelle Öffnungskraft pro Greiffinger 6 bar	.555 N	.1089 N
Betriebsdruck	.2-12 bar	.2-12 bar
Wiederholbarkeit	±0.05 mm	±0.05 mm
Gewicht	.6.5 Kg	.6 Kg
Betriebstemperatur	.5-60 °C	.5-60 °C
Artikelcode	.0E876PGE	.0E676PGS

<b>SPECIFICATIONS</b>	<b>OPE175-3</b>	<b>OPE175-3S</b>
Stroke per jaw	.30 mm	.15 mm
Piston stroke	.30 mm	.30 mm
Dual stroke air volume	.293 cm <sup>3</sup>	.293 cm <sup>3</sup>
Theoretical clamping force per jaw at 6 bar	.942 N	.1849 N
Actual clamping force per jaw at 6 bar	.520 N	.1047 N
Theoretical opening force per jaw at 6 bar	.1005 N	.1973 N
Actual opening force per jaw at 6 bar	.555 N	.1089 N
Working pressure	.2-12 bar	.2-12 bar
Reproducibility	±0.05 mm	±0.05 mm
Weight	.6.5 Kg	.6 Kg
Working temperature	.5-60 °C	.5-60 °C
Article code	.0E876PGE	.0E676PGS

<b>DONNÉES TECHNIQUES</b>	<b>OPE175-3</b>	<b>OPE175-3S</b>
Course par griffe	.30 mm	.15 mm
Course piston	.30 mm	.30 mm
Volume d'air pour course double	.293 cm <sup>3</sup>	.293 cm <sup>3</sup>
Force théorique en fermeture par griffe à 6 bar	.942 N	.1849 N
Force réelle en fermeture par griffe à 6 bar	.520 N	.1047 N
Force théorique en ouverture par griffe à 6 bar	.1005 N	.1973 N
Force réelle en ouverture par griffe à 6 bar	.555 N	.1089 N
Pression d'exercice	.2-12 bar	.2-12 bar
Répétibilité	±0.05 mm	±0.05 mm
Poids	.6.5 Kg	.6 Kg
Température d'exercice	.5-60 °C	.5-60 °C
Code article	.0E876PGE	.0E676PGS

OPE 205-3  
OPE 205-3 S

OPE 175-3  
OPE 175-3 S

OPE 125-3  
OPE 125-3 S

OPE 110-3  
OPE 110-3 S

OPE 105-3  
OPE 105-3 S

OPE 90-3  
OPE 90-3 S

OPE 80-3  
OPE 80-3 S

OPE 65-3  
OPE 65-3 S

OPE 60-3  
OPE 60-3 S



- **ORGANO DI PRESA A CORSA PARALLELA A TRE GRIFFE**
- **Three-jaw parallel gripper**
- **Drei-finger Parallelgreifer**
- **Pince de préhension à course parallèle, à trois griffes**

• Disegno OPE 205-3 • Drawing OPE 205-3 • Zeichnung OPE 205-3 • Dessin OPE 205-3

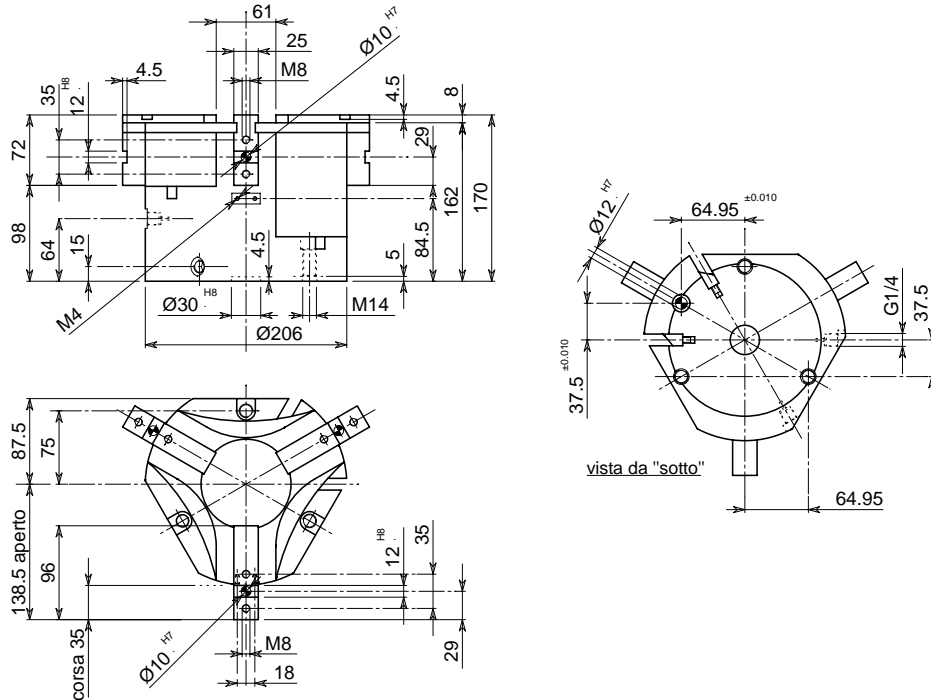

• Versione OPE 205-3 S • Version OPE 205-3 S • Ausführung OPE 205-3 S • Version OPE 205-3 S

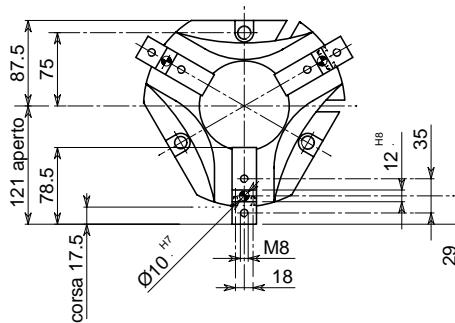

• Le dimensioni sono indicative e suscettibili di variazioni per migliorie tecniche. Ci riserviamo di apportare modifiche senza preavviso • All dimensions are indicative and subject to variation for technical upgrading. We reserve the right to make alterations without prior notification • Die Maßangaben sind indikativ und können sich bei technischen Verbesserung ändern. Wir behalten uns vor, ohne vorherige Benachrichtigung Änderungen vorzunehmen • Les dimensions sont fournies à titre indicatif, elles peuvent subir des variations pour cause d'améliorations techniques. Nous nous réservons le droit d'apporter des modifications sans préavis.

• SCHEMA DI FUNZIONAMENTO • OPERATIONAL DIAGRAM  
• BETRIEBSSCHEMA • SCHÉMA DE FONCTIONNEMENT

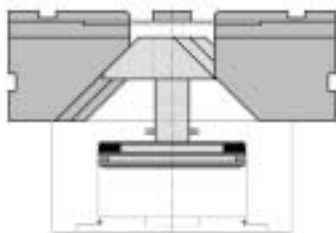

Aperto  
Open  
Geöffnet  
Ouvert

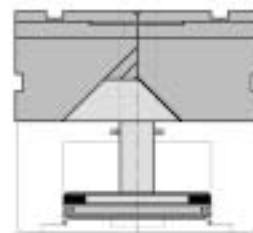

Chiuso  
Closed  
Geschlossen  
Fermé



- **ORGANO DI PRESA A CORSA PARALLELA A TRE GRIFFE**
- **Three-jaw parallel gripper**
- **Drei-finger Parallelgreifer**
- **Pince de préhension à course parallèle, à trois griffes**

**DIAGRAMMA FORZA DI CHIUSURA**  
**CLAMPING FORCE DIAGRAM • DIAGRAM SCHLIEßKRAFT**  
**DIAGRAMME DE LA FORCE DE FERMETURE**

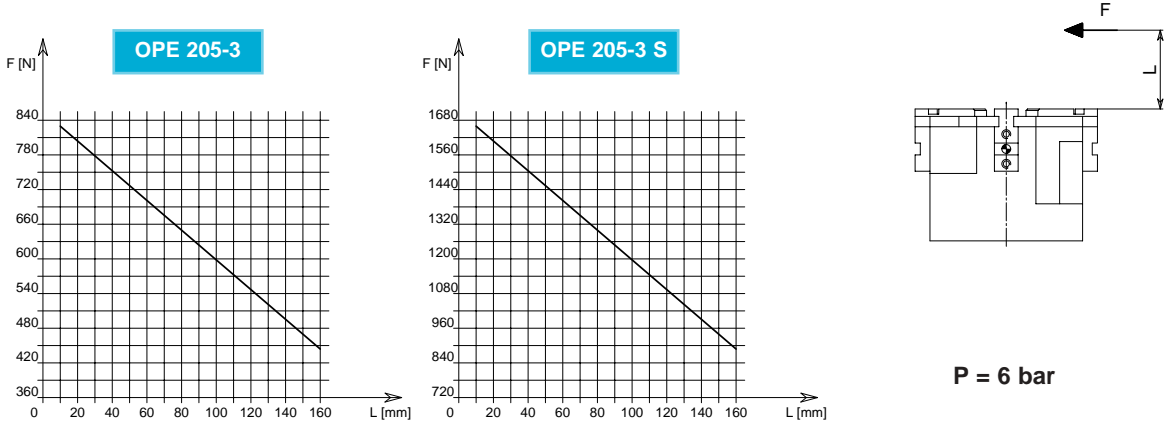

F = Forza di chiusura reale per griffa  
 L = Distanza di rilevamento

F = Reelle Schließkraft pro Greiffinger  
 L = Messungsabstand

F = True clamping force per jaw  
 L = Reading distance

F = Force de fermeture réelle par griffe  
 L = Distance de lecture

Valori nei dati tecnici rilevati alla distanza L = 20 mm • Technical specification values read at a distance L = 20 mm

• Werte der technischen Daten auf Distanz aufgenommen L = 20 mm • Valeurs des données techniques relevées à la distance L = 20 mm

DATI TECNICI	OPE205-3	OPE205-3S
Corsa per griffa	.35 mm	.17.5 mm
Corsa pistone	.35 mm	.35 mm
Volume aria per doppia corsa	.533 cm <sup>3</sup>	.533 cm <sup>3</sup>
Forza teorica di chiusura per griffa a 6 bar	.1470 N	.2885 N
Forza reale di chiusura per griffa a 6 bar	.805 N	.1580 N
Forza teorica di apertura per griffa a 6 bar	.1568 N	.3078 N
Forza reale di apertura per griffa a 6 bar	.859 N	.1686 N
Pressione di esercizio	.2-12 bar	.2-12 bar
Ripetibilità	±0.05 mm	±0.05 mm
Peso	.12 Kg	.11.5 Kg
Temperatura di esercizio	.5-60 °C	.5-60 °C
Codice articolo	.0E877PHE	.0E677PHS

TECHNISCHE DATEN	OPE205-3	OPE205-3S
Hub pro Greiffinger	.35 mm	.17.5 mm
Kolbenhub	.35 mm	.35 mm
Luftvolumen pro Doppelhub	.533 cm <sup>3</sup>	.533 cm <sup>3</sup>
Theoretische Schließkraft pro Greiffinger 6 bar	.1470 N	.2885 N
Reelle Schließkraft pro Greiffinger 6 bar	.805 N	.1580 N
Theoretische Öffnungskraft pro Greiffinger 6 bar	.1568 N	.3078 N
Reelle Öffnungskraft pro Greiffinger 6 bar	.859 N	.1686 N
Betriebsdruck	.2-12 bar	.2-12 bar
Wiederholbarkeit	±0.05 mm	±0.05 mm
Gewicht	.12 Kg	.11.5 Kg
Betriebstemperatur	.5-60 °C	.5-60 °C
Artikelcode	.0E877PHE	.0E677PHS

SPECIFICATIONS	OPE205-3	OPE205-3S
Stroke per jaw	.35 mm	.17.5 mm
Piston stroke	.35 mm	.35 mm
Dual stroke air volume	.533 cm <sup>3</sup>	.533 cm <sup>3</sup>
Theoretical clamping force per jaw at 6 bar	.1470 N	.2885 N
Actual clamping force per jaw at 6 bar	.805 N	.1580 N
Theoretical opening force per jaw at 6 bar	.1568 N	.3078 N
Actual opening force per jaw at 6 bar	.859 N	.1686 N
Working pressure	.2-12 bar	.2-12 bar
Reproducibility	±0.05 mm	±0.05 mm
Weight	.12 Kg	.11.5 Kg
Working temperature	.5-60 °C	.5-60 °C
Article code	.0E877PHE	.0E677PHS

DONNÉES TECHNIQUES	OPE205-3	OPE205-3S
Course par griffe	.35 mm	.17.5 mm
Course piston	.35 mm	.35 mm
Volume d'air pour course double	.533 cm <sup>3</sup>	.533 cm <sup>3</sup>
Force théorique en fermeture par griffe à 6 bar	.1470 N	.2885 N
Force réelle en fermeture par griffe à 6 bar	.805 N	.1580 N
Force théorique en ouverture par griffe à 6 bar	.1568 N	.3078 N
Force réelle en ouverture par griffe à 6 bar	.859 N	.1686 N
Pression d'exercice	.2-12 bar	.2-12 bar
Répétibilité	±0.05 mm	±0.05 mm
Poids	.12 Kg	.11.5 Kg
Température d'exercice	.5-60 °C	.5-60 °C
Code article	.0E877PHE	.0E677PHS

OPE 205-3  
OPE 205-3 S

OPE 175-3  
OPE 175-3 S

OPE 125-3  
OPE 125-3 S

OPE 110-3  
OPE 110-3 S

OPE 105-3  
OPE 105-3 S

OPE 90-3  
OPE 90-3 S

OPE 80-3  
OPE 80-3 S

OPE 65-3  
OPE 65-3 S

OPE 60-3  
OPE 60-3 S

- **CONTROLLO POSIZIONE APERTO-CHIUSO CON SENSORI (PROXIMITY) ESTERNI**
- **Open-closed control position with external proximity switches**
- **Positionskontrolle "geöffnet"- "geschlossen mit kontaktlosen Sensoren**
- **Contrôle de la position ouvert-fermé avec détecteurs extérieurs (de proximité)**

- **SCHEMA CON FISSAGGIO SUPERIORE**
- Top fixing diagram
- Oberseiteinspannung schema
- Schéma de fixation supérieure

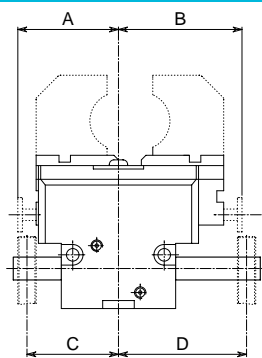

Sigla - Code Bezeichnung Sigle	A	B	C	D
<b>OPE 50</b>	33	38	29	40
<b>OPE 60</b>	37	44.5	33	46.5
<b>OPE 70</b>	44	54	40	56
<b>OPE 80</b>	48	60	44	62
<b>OPE 100</b>	60	70	56	72

- **SCHEMA CON FISSAGGIO LATERALE**
- Side fixing diagram
- Seiteinspannung schema
- Schéma de fixation sur le côté

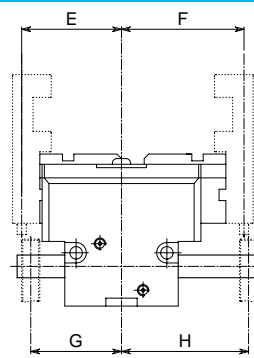

Sigla - Code Bezeichnung Sigle	A	B	C	D
<b>OPE 50 S</b>	33	35.5	29	37.5
<b>OPE 60 S</b>	37	40.75	33	42.75
<b>OPE 70 S</b>	44	49	40	51
<b>OPE 80 S</b>	48	54	44	56
<b>OPE 100 S</b>	60	65	56	67

- **STAFFA PORTA MICRO DI CONTROLLO**
- Control microswitch bracket
- Haltebügel Kontrollmikroschalter
- Etrier porte micro de contrôle

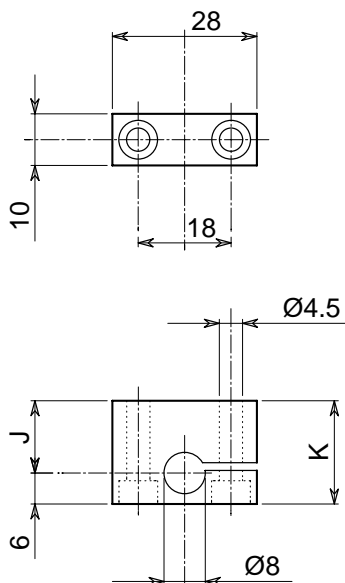

**Controllo chiuso**  
 Closed control  
 Contrôle fermé  
 Kontrolle geöffnet

Sigla Code Bezeichnung Sigle	Codice Article code Artikelcode Code article	
	J	K
<b>OPE 50</b>	7	13
<b>OPE 60</b>	8	14
<b>OPE 70</b>	15	21
<b>OPE 80</b>	13	19
<b>OPE 100</b>	6.5	12.5
<b>OPE 50 S</b>	7	13
<b>OPE 60 S</b>	8	14
<b>OPE 70 S</b>	15	21
<b>OPE 80 S</b>	13	19
<b>OPE 100 S</b>	6.5	12.5

**Controllo aperto**  
 Open control  
 Contrôle ouvert  
 Kontrolle geschlossen

Sigla Code Bezeichnung Sigle	Codice Article code Artikelcode Code article	
	J	K
<b>OPE 50</b>	18	24
<b>OPE 60</b>	21.5	27.5
<b>OPE 70</b>	31	37
<b>OPE 80</b>	31	37
<b>OPE 100</b>	22.5	28.5
<b>OPE 50 S</b>	15.5	21.5
<b>OPE 60 S</b>	17.75	23.75
<b>OPE 70 S</b>	26	32
<b>OPE 80 S</b>	25	31
<b>OPE 100 S</b>	17.5	23.5

• Le dimensioni sono indicative e suscettibili di variazioni per migliorie tecniche. Ci riserviamo di apportare modifiche senza preavviso • All dimensions are indicative and subject to variation for technical upgrading. We reserve the right to make alterations without prior notification • Die Maßangaben sind indikativ und können sich bei technischen Verbesserung ändern. Wir behalten uns vor, ohne vorherige Benachrichtigung Änderungen vorzunehmen • Les dimensions sont fournies à titre indicatif, elles peuvent subir des variations pour cause d'améliorations techniques. Nous nous réservons le droit d'apporter des modifications sans préavis.

- **CONTROLLO POSIZIONE APERTO-CHIUSO CON SENSORI (PROXIMITY) ESTERNI**
- **Open-closed control position with external proximity switches**
- **Positionskontrolle "geöffnet"- "geschlossen mit kontaktlosen Sensoren**
- **Contrôle de la position ouvert-fermé avec détecteurs extérieurs (de proximité)**

• **SCHEMA CON FISSAGGIO SUPERIORE**

- Top fixing diagram
- Oberseiteinspannung schema
- Schéma de fixation supérieur

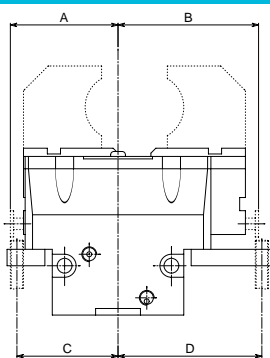

Sigla - Code Bezeichnung Sigle	A	B	C	D
<b>OPE 95</b>	55	70	51	72
<b>OPE 115</b>	65.5	85.5	61.5	87.5
<b>OPE 160</b>	89	119	85	121
<b>OPE 190</b>	104	139	100	141
<b>OPE 210</b>	114	154	110	156

• **SCHEMA CON FISSAGGIO LATERALE**

- Side fixing diagram
- Seiteinspannung schema
- Schéma de fixation sur le côté

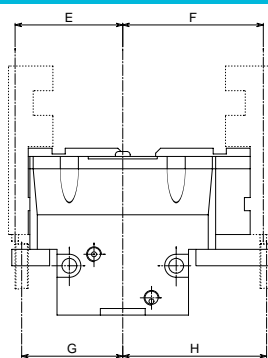

Sigla - Code Bezeichnung Sigle	A	B	C	D
<b>OPE 95 S</b>	55	62.5	51	64.5
<b>OPE 115 S</b>	65.5	75.5	61.5	77.5
<b>OPE 160 S</b>	89	104	85	106
<b>OPE 190 S</b>	104	121.5	100	123.5
<b>OPE 210 S</b>	114	134	110	136

• **STAFFA PORTA MICRO DI CONTROLLO**

- Control microswitch bracket
- Haltebügel Kontrollmikroschalter
- Etrier porte micro de contrôle

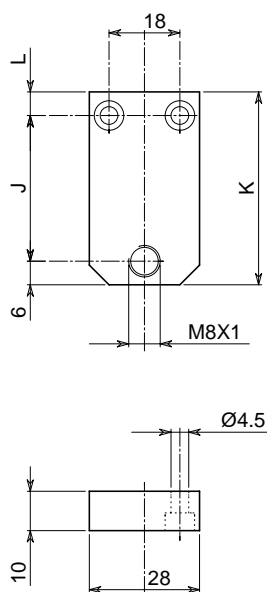

**Controllo chiuso**  
Closed control  
Contrôle fermé  
Kontrolle geöffnet

Sigla Code Bezeichnung Sigle	J	K	L	Codice Article code Artikelcode Code article
<b>OPE 95</b>	11	22	5	SC955CCH
<b>OPE 115</b>	11	23	6	SC115CCH
<b>OPE 160</b>	11	23	6	SC115CCH
<b>OPE 190</b>	11	23	6	SC115CCH
<b>OPE 210</b>	11	23	6	SC115CCH
<b>OPE 95 S</b>	11	22	5	SC955SCH
<b>OPE 115 S</b>	11	23	6	SC115CCH
<b>OPE 160 S</b>	11	23	6	SC115CCH
<b>OPE 190 S</b>	11	23	6	SC115CCH
<b>OPE 210 S</b>	11	23	6	SC115CCH

**Controllo aperto**  
Open control  
Contrôle ouvert  
Kontrolle geschlossen

Sigla Code Bezeichnung Sigle	J	K	L	Codice Article code Artikelcode Code article
<b>OPE 95</b>	32	43	5	SC955CAP
<b>OPE 115</b>	37	49	6	SC115CAP
<b>OPE 160</b>	47	59	6	SC168CAP
<b>OPE 190</b>	52	64	6	SC198CAP
<b>OPE 210</b>	57	69	6	SC210CAP
<b>OPE 95 S</b>	24.5	35.5	5	SC955SAP
<b>OPE 115 S</b>	27	39	6	SC115SAP
<b>OPE 160 S</b>	32	44	6	SC168SAP
<b>OPE 190 S</b>	34.5	46.5	6	SC198SAP
<b>OPE 210 S</b>	37	49	6	SC115CAP

• Le dimensioni sono indicative e suscettibili di variazioni per migliorie tecniche. Ci riserviamo di apportare modifiche senza preavviso • All dimensions are indicative and subject to variation for technical upgrading. We reserve the right to make alterations without prior notification • Die Maßangaben sind indikativ und können sich bei technischen Verbesserung ändern. Wir behalten uns vor, ohne vorherige Benachrichtigung Änderungen vorzunehmen • Les dimensions sont fournies à titre indicatif, elles peuvent subir des variations pour cause d'améliorations techniques. Nous nous réservons le droit d'apporter des modifications sans préavis.

- **CONTROLLO POSIZIONE APERTO-CHIUSO CON SENSORI (PROXIMITY) ESTERNI**
- **Open-closed control position with external proximity switches**
- **Positionskontrolle "geöffnet"- "geschlossen mit kontaktlosen Sensoren**
- **Contrôle de la position ouvert-fermé avec détecteurs extérieurs (de proximité)**

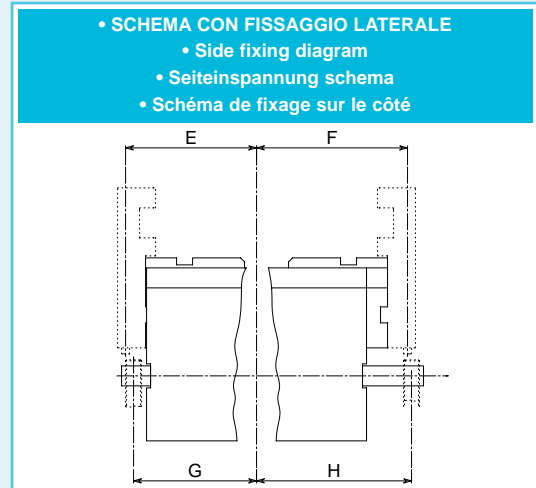
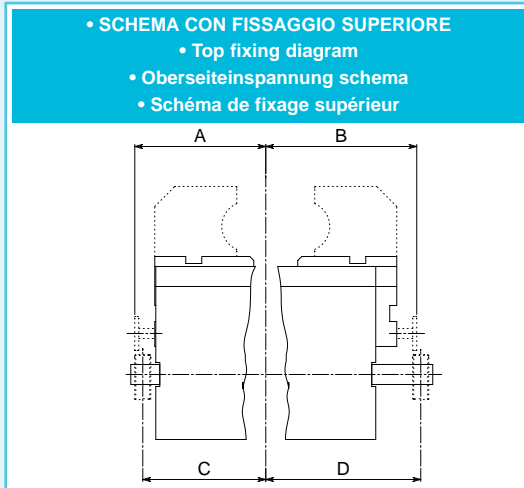

Sigla - Code Bezeichnung Sigle	A	B	C	D
OPE 60-3	39	44	35	46
OPE 65-3	43.5	51	39.5	53
OPE 80-3	50.5	60.5	46.5	62.5
OPE 90-3	55	67	51	69
OPE 105-3	62	77	58	79
OPE 110-3	65.5	75.5	61.5	77.5
OPE 125-3	73	93	69	95
OPE 175-3	97.5	127.5	93.5	129.5
OPE 205-3	113.5	148.5	109.5	150.5

Sigla - Code Bezeichnung Sigle	A	B	C	D
OPE 60-3 S	39	41.5	35	43.5
OPE 65-3 S	43.5	47.25	39.5	49.25
OPE 80-3 S	50.5	55.5	46.5	57.5
OPE 90-3 S	55	61	51	63
OPE 105-3 S	62	69.5	58	71.5
OPE 110-3 S	65.5	70.5	61.5	72.5
OPE 125-3 S	73	83	69	85
OPE 175-3 S	97.5	112.5	93.5	114.5
OPE 205-3 S	113.5	131.5	109.5	133

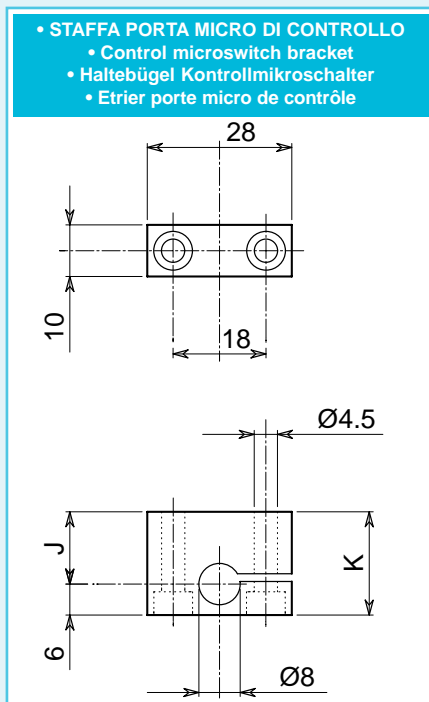

Sigla Code Bezeichnung Sigle	Controllo chiuso Closed control Contrôle fermé Kontrolle geöffnet			Controllo aperto Open control Contrôle ouvert Kontrolle geschlossen		
	J	K	Codice Aricle code Artikelcode Code article	J	K	Codice Aricle code Artikelcode Code article
OPE 60-3	10.5	16.5	SC603CCH	21.5	27.5	SC603CAP
OPE 65-3	10	16	SC654CCH	23.5	29.5	SC654CAP
OPE 80-3	9.5	15.5	SC843CCH	25.5	31.5	SC843CAP
OPE 90-3	9	15	SC945CCH	27	33	SC945CAP
OPE 105-3	8.5	14.5	SC105CCH	29.5	35.5	SC105CAP
OPE 110-3	8.5	14.5	SC105CCH	24.5	30.5	SC110CAP
OPE 125-3	8	14	SC603CCH	34	40	SC127CAP
OPE 175-3	8	14	SC603CCH	44	50	SC175CAP
OPE 205-3	7.5	13.5	SC205CCH	48.5	54.5	SC205CAP
OPE 60-3 S	10.5	16.5	SC603CCH	19	25	SC603SAP
OPE 65-3 S	10	16	SC654CCH	19.75	25.75	SC654SAP
OPE 80-3 S	9.5	15.5	SC843CCH	20.5	26.5	SC843SAP
OPE 90-3 S	9	15	SC945CCH	21	27	SC945SAP
OPE 105-3 S	8.5	14.5	SC105CCH	22	28	SC105SAP
OPE 110-3 S	8.5	14.5	SC105CCH	19.5	25.5	SC110SAP
OPE 125-3 S	8	14	SC603CCH	24	30	SC127SAP
OPE 175-3 S	8	14	SC603CCH	29	35	SC175SAP
OPE 205-3 S	7.5	13.5	SC205CCH	31	37	SC704CAP

• Le dimensioni sono indicative e suscettibili di variazioni per migliorie tecniche. Ci riserviamo di apportare modifiche senza preavviso • All dimensions are indicative and subject to variation for technical upgrading. We reserve the right to make alterations without prior notification • Die Maßangaben sind indikativ und können sich bei technischen Verbesserung ändern. Wir behalten uns vor, ohne vorherige Benachrichtigung Änderungen vorzunehmen • Les dimensions sont fournies à titre indicatif, elles peuvent subir des variations pour cause d'améliorations techniques. Nous nous réservons le droit d'apporter des modifications sans préavis.

- **DISPOSITIVO DI SICUREZZA CON MOLLA**
- **Safety device with spring**
- **Sicherheits-vorrichtung mit Feder**
- **Dispositif de sécurité avec ressort**

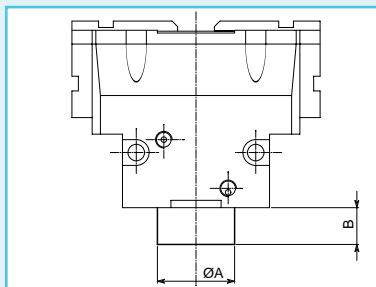

SIGLA	A	B	Forza reale di chiusura per griffa con sola molla - N	Forza totale reale di chiusura per griffa a 6 bar - N (a pinza chiusa)	Peso Kg	Press. min. bar	Press. max. bar	CODICE
OPE 50 CM	18	12	9 - 19	64	0.26	3	10	OE770NRE
OPE 60 CM	22	15	15 - 29	92	0.44	3	10	OE771NBE
OPE 70 CM	22	15	15 - 34	92	0.51	3	10	OE772NCE
OPE 80 CM	28	18	26 - 52	137	0.62	3.5	10	OE773NDE
OPE 95 CM	32	22	34 - 74	184	1.05	4	10	OE774NEE
OPE 100 CM	55	22	133 - 201	777	2.1	3	10	OE779MLE
OPE 115 CM	42	25	53 - 88	307	2	3	10	OE775NFE
OPE 160 CM	55	26	80 - 210	594	3.85	3.5	10	OE776MGE
OPE 190 CM	65	35	111 - 300	735	7.1	4	10	OE777NHE
OPE 210 CM	74	40	130 - 242	976	11.1	3	10	OE778NIE

CODE	A	B	True clamping force per jaw only with spring - N	Total true clamping force per jaw to 6 bar N (with closed gripper)	Weight Kg	Min pressure bar	Max pressure bar	ARTICLE CODE
OPE 50 CM	18	12	9 - 19	64	0.26	3	10	OE770NRE
OPE 60 CM	22	15	15 - 29	92	0.44	3	10	OE771NBE
OPE 70 CM	22	15	15 - 34	92	0.51	3	10	OE772NCE
OPE 80 CM	28	18	26 - 52	137	0.62	3.5	10	OE773NDE
OPE 95 CM	32	22	34 - 74	184	1.05	4	10	OE774NEE
OPE 100 CM	55	22	133 - 201	777	2.1	3	10	OE779MLE
OPE 115 CM	42	25	53 - 88	307	2	3	10	OE775NFE
OPE 160 CM	55	26	80 - 210	594	3.85	3.5	10	OE776MGE
OPE 190 CM	65	35	111 - 300	735	7.1	4	10	OE777NHE
OPE 210 CM	74	40	130 - 242	976	11.1	3	10	OE778NIE

BEZEICHNUNG	A	B	Reele Schliesskraft pro Backe nur mit Feder - N	Reele Gesamtschliesskraft pro Backe (mit geschlossenem Greifer 6 bar - N)	Gewicht Kg	Min Druck bar	Max Druck bar	ARTIKEL CODE
OPE 50 CM	18	12	9 - 19	64	0.26	3	10	OE770NRE
OPE 60 CM	22	15	15 - 29	92	0.44	3	10	OE771NBE
OPE 70 CM	22	15	15 - 34	92	0.51	3	10	OE772NCE
OPE 80 CM	28	18	26 - 52	137	0.62	3.5	10	OE773NDE
OPE 95 CM	32	22	34 - 74	184	1.05	4	10	OE774NEE
OPE 100 CM	55	22	133 - 201	777	2.1	3	10	OE779MLE
OPE 115 CM	42	25	53 - 88	307	2	3	10	OE775NFE
OPE 160 CM	55	26	80 - 210	594	3.85	3.5	10	OE776MGE
OPE 190 CM	65	35	111 - 300	735	7.1	4	10	OE777NHE
OPE 210 CM	74	40	130 - 242	976	11.1	3	10	OE778NIE

SIGLE	A	B	Force réelle en fermeture par griffe seulement avec ressort - N	Totale force réelle en fermeture par griffe 6 bar N (avec la pince fermée)	Poids Kg	Min press. bar	Max press. bar	CODE ARTICLE
OPE 50 CM	18	12	9 - 19	64	0.26	3	10	OE770NRE
OPE 60 CM	22	15	15 - 29	92	0.44	3	10	OE771NBE
OPE 70 CM	22	15	15 - 34	92	0.51	3	10	OE772NCE
OPE 80 CM	28	18	26 - 52	137	0.62	3.5	10	OE773NDE
OPE 95 CM	32	22	34 - 74	184	1.05	4	10	OE774NEE
OPE 100 CM	55	22	133 - 201	777	2.1	3	10	OE779MLE
OPE 115 CM	42	25	53 - 88	307	2	3	10	OE775NFE
OPE 160 CM	55	26	80 - 210	594	3.85	3.5	10	OE776MGE
OPE 190 CM	65	35	111 - 300	735	7.1	4	10	OE777NHE
OPE 210 CM	74	40	130 - 242	976	11.1	3	10	OE778NIE

**Nota:** versione con molla in chiusura, su richiesta fornibile con molla in apertura

**Note:** type with spring in clamping, on request available with spring in opening

**Anmerkung:** Typ mit Feder in Geöfnung, nach Frage mit Feder in Öffnung

**Note:** type avec ressort en fermeture, sur demande ou peut le fournir avec ressort en ouverture

• Le dimensioni sono indicative e suscettibili di variazioni per migliorie tecniche. Ci riserviamo di apportare modifiche senza preavviso • All dimensions are indicative and subject to variation for technical upgrading. We reserve the right to make alterations without prior notification • Die Maßangaben sind indikativ und können sich bei technischen Verbesserung ändern. Wir behalten uns vor, ohne vorherige Benachrichtigung Änderungen vorzunehmen • Les dimensions sont fournies à titre indicatif, elles peuvent subir des variations pour cause d'améliorations techniques. Nous nous réservons le droit d'apporter des modifications sans préavis.

• **ORGANI DI PRESA A CORSA PARALLELA A DUE GRIFFE OPE • Two-jaw parallel grippers OPE**  
 • **Zwei-finger Parallelgreifer OPE • Pincas de préhension à course parallèle, à deux griffes OPE**

- **DISPOSITIVO DI SICUREZZA CON MOLLA**
- **Safety device with spring**
- **Sicherheits-vorrichtung mit Feder**
- **Dispositif de sécurité avec ressort**

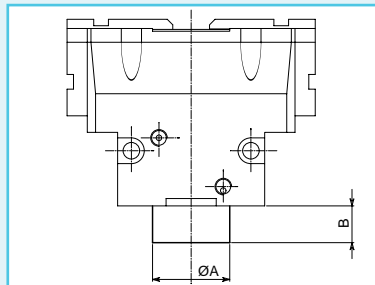

SIGLA	A	B	Forza reale di chiusura per griffa con sola molla - N	Forza totale reale di chiusura per griffa a 6 bar - N (a pinza chiusa)	Peso Kg	Press. min. bar	Press. max. bar	CODICE
OPE 50 SCM	18	12	15 - 31	105	0.26	3	10	OE970NRS
OPE 60 SCM	22	15	29 - 57	182	0.44	3	10	OE971NBS
OPE 70 SCM	22	15	29 - 66	182	0.51	3	10	OE972NCS
OPE 80 SCM	28	18	51 - 101	268	0.62	3.5	10	OE973NDS
OPE 95 SCM	32	22	66 - 147	361	1.05	4	10	OE974NES
OPE 100 SCM	55	22	260 - 395	1524	2.1	3	10	OE979MLS
OPE 115 SCM	42	25	105 - 174	602	2	3	10	OE975NFS
OPE 160 SCM	55	26	156 - 411	1167	3.85	3.5	10	OE976MGS
OPE 190 SCM	65	35	218 - 588	1442	7.1	4	10	OE977NHS
OPE 210 SCM	74	40	255 - 474	1915	11.1	3	10	OE978NIS

CODE	A	B	True clamping force per jaw only with spring - N	Total true clamping force per jaw to 6 bar N (with closed gripper)	Weight Kg	Min pressure bar	Max pressure bar	ARTICLE CODE
OPE 50 SCM	18	12	15 - 31	105	0.26	3	10	OE970NRS
OPE 60 SCM	22	15	29 - 57	182	0.44	3	10	OE971NBS
OPE 70 SCM	22	15	29 - 66	182	0.51	3	10	OE972NCS
OPE 80 SCM	28	18	51 - 101	268	0.62	3.5	10	OE973NDS
OPE 95 SCM	32	22	66 - 147	361	1.05	4	10	OE974NES
OPE 100 SCM	55	22	260 - 395	1524	2.1	3	10	OE979MLS
OPE 115 SCM	42	25	105 - 174	602	2	3	10	OE975NFS
OPE 160 SCM	55	26	156 - 411	1167	3.85	3.5	10	OE976MGS
OPE 190 SCM	65	35	218 - 588	1442	7.1	4	10	OE977NHS
OPE 210 SCM	74	40	255 - 474	1915	11.1	3	10	OE978NIS

BEZEICHNUNG	A	B	Reele Schliesskraft pro Backe nur mit Feder - N	Reele Gesamtschliesskraft pro Backe (mit geschlossenen Greifer 6 bar - N)	Gewicht Kg	Min Druck bar	Max Druck bar	ARTIKEL CODE
OPE 50 SCM	18	12	15 - 31	105	0.26	3	10	OE970NRS
OPE 60 SCM	22	15	29 - 57	182	0.44	3	10	OE971NBS
OPE 70 SCM	22	15	29 - 66	182	0.51	3	10	OE972NCS
OPE 80 SCM	28	18	51 - 101	268	0.62	3.5	10	OE973NDS
OPE 95 SCM	32	22	66 - 147	361	1.05	4	10	OE974NES
OPE 100 SCM	55	22	260 - 395	1524	2.1	3	10	OE979MLS
OPE 115 SCM	42	25	105 - 174	602	2	3	10	OE975NFS
OPE 160 SCM	55	26	156 - 411	1167	3.85	3.5	10	OE976MGS
OPE 190 SCM	65	35	218 - 588	1442	7.1	4	10	OE977NHS
OPE 210 SCM	74	40	255 - 474	1915	11.1	3	10	OE978NIS

SIGLE	A	B	Force réelle en fermeture par griffe seulement avec ressort - N	Totale force réelle en fermeture par griffe 6 bar N (avec la pince fermée)	Poids Kg	Min press. bar	Max press. bar	CODE ARTICLE
OPE 50 SCM	18	12	15 - 31	105	0.26	3	10	OE970NRS
OPE 60 SCM	22	15	29 - 57	182	0.44	3	10	OE971NBS
OPE 70 SCM	22	15	29 - 66	182	0.51	3	10	OE972NCS
OPE 80 SCM	28	18	51 - 101	268	0.62	3.5	10	OE973NDS
OPE 95 SCM	32	22	66 - 147	361	1.05	4	10	OE974NES
OPE 100 SCM	55	22	260 - 395	1524	2.1	3	10	OE979MLS
OPE 115 SCM	42	25	105 - 174	602	2	3	10	OE975NFS
OPE 160 SCM	55	26	156 - 411	1167	3.85	3.5	10	OE976MGS
OPE 190 SCM	65	35	218 - 588	1442	7.1	4	10	OE977NHS
OPE 210 SCM	74	40	255 - 474	1915	11.1	3	10	OE978NIS

**Nota:** versione con molla in chiusura, su richiesta fornibile con molla in apertura

**Note:** type with spring in clamping, on request available with spring in opening

**Anmerkung:** Typ mit Feder in Geöfnung, nach Frage mit Feder in Öffnung

**Note:** type avec ressort en fermeture, sur demande ou peut le fournir avec ressort en ouverture

• Le dimensioni sono indicative e suscettibili di variazioni per migliorie tecniche. Ci riserviamo di apportare modifiche senza preavviso • All dimensions are indicative and subject to variation for technical upgrading. We reserve the right to make alterations without prior notification • Die Maßangaben sind inklinativ und können sich bei technischen Verbesserungen ändern. Wir behalten uns vor, ohne vorherige Benachrichtigung, Änderungen vorzunehmen • Les dimensions sont fournies à titre indicatif; elles peuvent subir des variations pour cause d'améliorations techniques. Nous nous réservons le droit d'apporter des modifications sans préavis.

- **DISPOSITIVO DI SICUREZZA CON MOLLA**
- **Safety device with spring**
- **Sicherheits-vorrichtung mit Feder**
- **Dispositif de sécurité avec ressort**

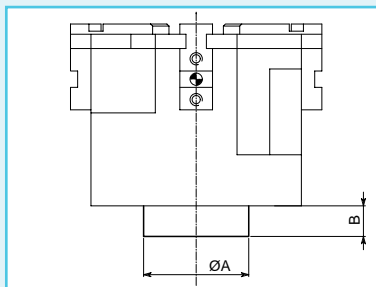

SIGLA	A	B	Forza reale di chiusura per griffa con sola molla - N	Forza totale reale di chiusura per griffa a 6 bar - N (a pinza chiusa)	Peso Kg	Press. min. bar	Press. max. bar	CODICE
OPE 60-3 CM	30	14	15 - 19	96	0.67	3	10	OE870NRE
OPE 65-3 CM	35	16.5	20 - 30	147	0.78	3	10	OE871NBE
OPE 80-3 CM	35	16.5	17 - 30	144	1.03	3	10	OE872NCE
OPE 90-3 CM	40	21	31 - 52	186	1.35	3	10	OE873NDE
OPE 105-3 CM	45	22	42 - 76	237	2.17	3.5	10	OE874NEE
OPE 110-3 CM	55	25	68 - 110	383	3	3	10	OE879NLE
OPE 125-3 CM	65	29	78 - 182	471	4	4	10	OE875NFE
OPE 175-3 CM	75	37	81 - 180	589	6.9	3	10	OE876NGE
OPE 205-3 CM	80	40	88 - 148	882	12.8	3	10	OE877NHE

CODE	A	B	True clamping force per jaw only with spring - N	Total true clamping force per jaw to 6 bar N (with closed gripper)	Weight Kg	Min pressure bar	Max pressure bar	ARTICLE CODE
OPE 60-3 CM	30	14	15 - 19	96	0.67	3	10	OE870NRE
OPE 65-3 CM	35	16.5	20 - 30	147	0.78	3	10	OE871NBE
OPE 80-3 CM	35	16.5	17 - 30	144	1.03	3	10	OE872NCE
OPE 90-3 CM	40	21	31 - 52	186	1.35	3	10	OE873NDE
OPE 105-3 CM	45	22	42 - 76	237	2.17	3.5	10	OE874NEE
OPE 110-3 CM	55	25	68 - 110	383	3	3	10	OE879NLE
OPE 125-3 CM	65	29	78 - 182	471	4	4	10	OE875NFE
OPE 175-3 CM	75	37	81 - 180	589	6.9	3	10	OE876NGE
OPE 205-3 CM	80	40	88 - 148	882	12.8	3	10	OE877NHE

BEZEICHNUNG	A	B	Reele Schliesskraft pro Backe nur mit Feder - N	Reele Gesamtschliesskraft pro Backe (mit geschlossenen Greifer 6 bar - N)	Gewicht Kg	Min Druck bar	Max Druck bar	ARTIKEL CODE
OPE 60-3 CM	30	14	15 - 19	96	0.67	3	10	OE870NRE
OPE 65-3 CM	35	16.5	20 - 30	147	0.78	3	10	OE871NBE
OPE 80-3 CM	35	16.5	17 - 30	144	1.03	3	10	OE872NCE
OPE 90-3 CM	40	21	31 - 52	186	1.35	3	10	OE873NDE
OPE 105-3 CM	45	22	42 - 76	237	2.17	3.5	10	OE874NEE
OPE 110-3 CM	55	25	68 - 110	383	3	3	10	OE879NLE
OPE 125-3 CM	65	29	78 - 182	471	4	4	10	OE875NFE
OPE 175-3 CM	75	37	81 - 180	589	6.9	3	10	OE876NGE
OPE 205-3 CM	80	40	88 - 148	882	12.8	3	10	OE877NHE

SIGLE	A	B	Force réelle en fermeture par griffe seulement avec ressort - N	Totale force réelle en fermeture par griffe 6 bar N (avec la pince fermée)	Poids Kg	Min press. bar	Max press. bar	CODE ARTICLE
OPE 60-3 CM	30	14	15 - 19	96	0.67	3	10	OE870NRE
OPE 65-3 CM	35	16.5	20 - 30	147	0.78	3	10	OE871NBE
OPE 80-3 CM	35	16.5	17 - 30	144	1.03	3	10	OE872NCE
OPE 90-3 CM	40	21	31 - 52	186	1.35	3	10	OE873NDE
OPE 105-3 CM	45	22	42 - 76	237	2.17	3.5	10	OE874NEE
OPE 110-3 CM	55	25	68 - 110	383	3	3	10	OE879NLE
OPE 125-3 CM	65	29	78 - 182	471	4	4	10	OE875NFE
OPE 175-3 CM	75	37	81 - 180	589	6.9	3	10	OE876NGE
OPE 205-3 CM	80	40	88 - 148	882	12.8	3	10	OE877NHE

**Nota:** versione con molla in chiusura, su richiesta fornibile con molla in apertura

**Note:** type with spring in clamping, on request available with spring in opening

**Anmerkung:** Typ mit Feder in Geöfnung, nach Frage mit Feder in Öffnung

**Note:** type avec ressort en fermeture, sur demande ou peut le fournir avec ressort en ouverture

• Le dimensioni sono indicative e suscettibili di variazioni per migliorie tecniche. Ci riserviamo di apportare modifiche senza preavviso • All dimensions are indicative and subject to variation for technical upgrading. We reserve the right to make alterations without prior notification • Die Maßangaben sind indikativ und können sich bei technischen Verbesserungen ändern. Wir behalten uns vor ohne vorherige Benachrichtigung Änderungen vorzunehmen • Les dimensions sont fournies à titre indicatif, elles peuvent subir des variations pour cause d'améliorations techniques. Nous nous réservons le droit d'apporter des modifications sans préavis.

• **ORGANI DI PRESA A CORSA PARALLELA A TRE GRIFFE • Three-jaw parallel grippers**  
 • **3 Finger-Greiferen mit Parallelbewegung • Pincas de préhension à course parallèle, à trois griffes**

- **DISPOSITIVO DI SICUREZZA CON MOLLA**
- **Safety device with spring**
- **Sicherheits-vorrichtung mit Feder**
- **Dispositif de sécurité avec ressort**

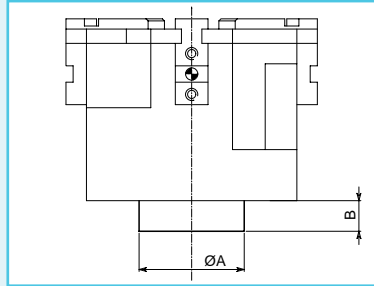

SIGLA	A	B	Forza reale di chiusura per griffa con sola molla - N	Forza totale reale di chiusura per griffa a 6 bar - N (a pinza chiusa)	Peso Kg	Press. min. bar	Press. max. bar	CODICE
OPE 60-3 SCM	30	14	25 - 31	158	0.57	3	10	OE670NRS
OPE 65-3 SCM	35	16.5	40 - 60	290	0.68	3	10	OE671NBS
OPE 80-3 SCM	35	16.5	34 - 60	283	0.93	3	10	OE672NCS
OPE 90-3 SCM	40	21	62 - 102	366	1.25	3	10	OE673NDS
OPE 105-3 SCM	45	22	82 - 149	465	1.92	3.5	10	OE674NES
OPE 110-3 SCM	55	25	135 - 217	752	2.6	3	10	OE679NLS
OPE 125-3 SCM	65	29	153 - 357	925	3.25	4	10	OE675NFS
OPE 175-3 SCM	75	27	159 - 354	1156	6.4	3	10	OE676NGS
OPE 205-3 SCM	80	40	173 - 290	1732	12.3	3	10	OE677NHS

CODE	A	B	True clamping force per jaw only with spring - N	Total true clamping force per jaw to 6 bar N (with closed gripper)	Weight Kg	Min pressure bar	Max pressure bar	ARTICLE CODE
OPE 60-3 SCM	30	14	25 - 31	158	0.57	3	10	OE670NRS
OPE 65-3 SCM	35	16.5	40 - 60	290	0.68	3	10	OE671NBS
OPE 80-3 SCM	35	16.5	34 - 60	283	0.93	3	10	OE672NCS
OPE 90-3 SCM	40	21	62 - 102	366	1.25	3	10	OE673NDS
OPE 105-3 SCM	45	22	82 - 149	465	1.92	3.5	10	OE674NES
OPE 110-3 SCM	55	25	135 - 217	752	2.6	3	10	OE679NLS
OPE 125-3 SCM	65	29	153 - 357	925	3.25	4	10	OE675NFS
OPE 175-3 SCM	75	27	159 - 354	1156	6.4	3	10	OE676NGS
OPE 205-3 SCM	80	40	173 - 290	1732	12.3	3	10	OE677NHS

BEZEICHNUNG	A	B	Reele Schliesskraft pro Backe nur mit Feder - N	Reele Gesamtschliesskraft pro Backe (mit geschossenem Greifer 6 bar - N)	Gewicht Kg	Min Druck bar	Max Druck bar	ARTIKEL CODE
OPE 60-3 SCM	30	14	25 - 31	158	0.57	3	10	OE670NRS
OPE 65-3 SCM	35	16.5	40 - 60	290	0.68	3	10	OE671NBS
OPE 80-3 SCM	35	16.5	34 - 60	283	0.93	3	10	OE672NCS
OPE 90-3 SCM	40	21	62 - 102	366	1.25	3	10	OE673NDS
OPE 105-3 SCM	45	22	82 - 149	465	1.92	3.5	10	OE674NES
OPE 110-3 SCM	55	25	135 - 217	752	2.6	3	10	OE679NLS
OPE 125-3 SCM	65	29	153 - 357	925	3.25	4	10	OE675NFS
OPE 175-3 SCM	75	27	159 - 354	1156	6.4	3	10	OE676NGS
OPE 205-3 SCM	80	40	173 - 290	1732	12.3	3	10	OE677NHS

SIGLE	A	B	Force réelle en fermeture par griffe seulement avec ressort - N	Totale force réelle en fermeture par griffe 6 bar N (avec la pince fermée)	Poids Kg	Min press. bar	Max press. bar	CODE ARTICLE
OPE 60-3 SCM	30	14	25 - 31	158	0.57	3	10	OE670NRS
OPE 65-3 SCM	35	16.5	40 - 60	290	0.68	3	10	OE671NBS
OPE 80-3 SCM	35	16.5	34 - 60	283	0.93	3	10	OE672NCS
OPE 90-3 SCM	40	21	62 - 102	366	1.25	3	10	OE673NDS
OPE 105-3 SCM	45	22	82 - 149	465	1.92	3.5	10	OE674NES
OPE 110-3 SCM	55	25	135 - 217	752	2.6	3	10	OE679NLS
OPE 125-3 SCM	65	29	153 - 357	925	3.25	4	10	OE675NFS
OPE 175-3 SCM	75	27	159 - 354	1156	6.4	3	10	OE676NGS
OPE 205-3 SCM	80	40	173 - 290	1732	12.3	3	10	OE677NHS

**Nota:** versione con molla in chiusura, su richiesta fornibile con molla in apertura

**Note:** type with spring in clamping, on request available with spring in opening

**Anmerkung:** Typ mit Feder in Geöfnung, nach Frage mit Feder in Öffnung

**Note:** type avec ressort en fermeture, sur demande ou peut le fournir avec ressort en ouverture

• Le dimensioni sono indicative e suscettibili di variazioni per migliorie tecniche. Ci riserviamo di apportare modifiche senza preavviso • All dimensions are indicative and subject to variation for technical upgrading. We reserve the right to make alterations without prior notification • Die Maßangaben sind indikativ und können sich bei technischen Verbesserung ändern. Wir behalten uns vor ohne vorherige Benachrichtigung Änderungen vorzunehmen • Les dimensions sont fournies à titre indicatif, elles peuvent subir des variations pour cause d'améliorations techniques. Nous nous réservons le droit d'apporter des modifications sans préavis.

- **DISPOSITIVO STABILIZZATORE PEZZO**
- **Workpiece stabilizer**
- **Vorrichtung zur Stabilisierung des Werkstückes**
- **Dispositif stabilisateur de la pièce**

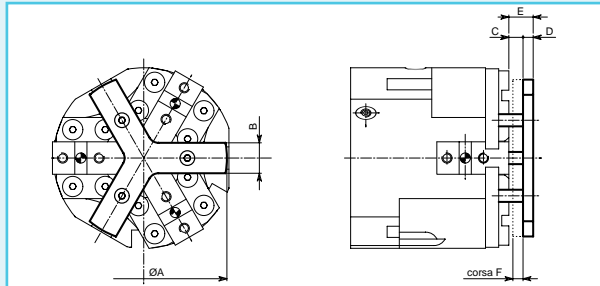

SIGLA	A	B	C	D	E	F	Forza espressa dalle molle N	Peso Kg	CODICE
KIST 60-3 / ...S	53	11	6	4	10	4	8.5...17	0.05	KS603ABA
KIST 65-3 / ...S	63	13	6	4	10	4	9...44	0.06	KS654ABB
KIST 80-3 / ...S	73	13	6	4	10	4	9...44	0.07	KS804ABC
KIST 90-3 / ...S	82	15	7	5	12	5	18...77	0.10	KS904ABD
KIST 105-3 / ...S	89	15	7	5	12	5	18...77	0.12	KS105ABE
KIST 110-3 / ...S	98	19	7	6	13	5	36...245	0.18	KS110ABF
KIST 125-3 / ...S	108	17	8	7	15	6	36...245	0.20	KS125ABG
KIST 175-3 / ...S	138	20	8	7	15	6	162...439	0.30	KS175ABH
KIST 205-3 / ...S	173	24	8	8	16	6	162...439	0.45	KS205ABI

CODE	A	B	C	D	E	F	Force expressed by springs N	Weight Kg	ARTICLE CODE
KIST 60-3 / ...S	53	11	6	4	10	4	8.5...17	0.05	KS603ABA
KIST 65-3 / ...S	63	13	6	4	10	4	9...44	0.06	KS654ABB
KIST 80-3 / ...S	73	13	6	4	10	4	9...44	0.07	KS804ABC
KIST 90-3 / ...S	82	15	7	5	12	5	18...77	0.10	KS904ABD
KIST 105-3 / ...S	89	15	7	5	12	5	18...77	0.12	KS105ABE
KIST 110-3 / ...S	98	19	7	6	13	5	36...245	0.18	KS110ABF
KIST 125-3 / ...S	108	17	8	7	15	6	36...245	0.20	KS125ABG
KIST 175-3 / ...S	138	20	8	7	15	6	162...439	0.30	KS175ABH
KIST 205-3 / ...S	173	24	8	8	16	6	162...439	0.45	KS205ABI

BEZEICHNUNG	A	B	C	D	E	F	Kraft der federn N	Gewicht Kg	ARTIKELCODE
KIST 60-3 / ...S	53	11	6	4	10	4	8.5...17	0.05	KS603ABA
KIST 65-3 / ...S	63	13	6	4	10	4	9...44	0.06	KS654ABB
KIST 80-3 / ...S	73	13	6	4	10	4	9...44	0.07	KS804ABC
KIST 90-3 / ...S	82	15	7	5	12	5	18...77	0.10	KS904ABD
KIST 105-3 / ...S	89	15	7	5	12	5	18...77	0.12	KS105ABE
KIST 110-3 / ...S	98	19	7	6	13	5	36...245	0.18	KS110ABF
KIST 125-3 / ...S	108	17	8	7	15	6	36...245	0.20	KS125ABG
KIST 175-3 / ...S	138	20	8	7	15	6	162...439	0.30	KS175ABH
KIST 205-3 / ...S	173	24	8	8	16	6	162...439	0.45	KS205ABI

SIGLE	A	B	C	D	E	F	Force exprimée par les ressorts N	Poids Kg	CODE ARTICLE
KIST 60-3 / ...S	53	11	6	4	10	4	8.5...17	0.05	KS603ABA
KIST 65-3 / ...S	63	13	6	4	10	4	9...44	0.06	KS654ABB
KIST 80-3 / ...S	73	13	6	4	10	4	9...44	0.07	KS804ABC
KIST 90-3 / ...S	82	15	7	5	12	5	18...77	0.10	KS904ABD
KIST 105-3 / ...S	89	15	7	5	12	5	18...77	0.12	KS105ABE
KIST 110-3 / ...S	98	19	7	6	13	5	36...245	0.18	KS110ABF
KIST 125-3 / ...S	108	17	8	7	15	6	36...245	0.20	KS125ABG
KIST 175-3 / ...S	138	20	8	7	15	6	162...439	0.30	KS175ABH
KIST 205-3 / ...S	173	24	8	8	16	6	162...439	0.45	KS205ABI

• Le dimensioni sono indicative e suscettibili di variazioni per migliorie tecniche. Ci riserviamo di apportare modifiche senza preavviso • All dimensions are indicative and subject to variation for technical upgrading. We reserve the right to make alterations without prior notification • Die Maßangaben sind indikativ und können sich bei technischen Verbesserungen ändern. Wir behalten uns vor, ohne vorherige Benachrichtigung Änderungen vorzunehmen • Les dimensions sont fournies à titre indicatif, elles peuvent subir des variations pour cause d'améliorations techniques. Nous nous réservons le droit d'apporter des modifications sans préavis.

• **ORGANI DI PRESA A CORSA PARALLELA A TRE GRIFFE OPE** • **Three-jaw parallel grippers OPE**  
 • **Drei-finger Parallelgreifer OPE** • **Pinces de préhension à course parallèle, à trois griffes OPE**

• **ALIMENTAZIONE ASSIALE**  
 • **Axial feed**  
 • **Achsenrechte Zufuhr**  
 • **Alimentation axiale**

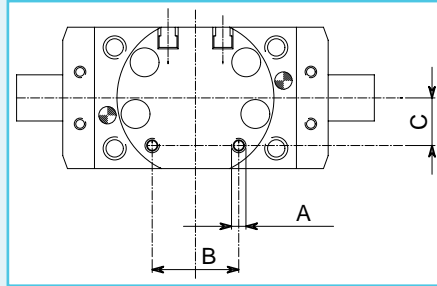

Sigla Code Bezeichnung Sigle	A	B	C	Codice Article code Artikelcode Code article	Sigla Code Bezeichnung Sigle	A	B	C	Codice Article code Artikelcode Code article
OPE 50 X	M3	17	10.5	OE770PXA	OPE 50 SX	M3	17	10.5	OE970PXM
OPE 60 X	M3	19	12.6	OE771PXB	OPE 60 SX	M3	19	12.6	OE971PXN
OPE 70 X	M3	19	12.6	OE772PXC	OPE 70 SX	M3	19	12.6	OE972PXO
OPE 80 X	M3	22	14.5	OE773PXD	OPE 80 SX	M3	22	14.5	OE973PXP
OPE 95 X	M3	30	16.5	OE774PXE	OPE 95 SX	M3	30	16.5	OE974PXQ
OPE 100 X	M4	53	30	OE779PXF	OPE 100 SX	M4	53	30	OE979PXR
OPE 115 X	M4	35	21	OE775PXG	OPE 115 SX	M4	35	21	OE975PXS
OPE 160 X	M4	50	28	OE776PXH	OPE 160 SX	M4	50	28	OE976PXT
OPE 190 X	M4	60	27.5	OE777PXI	OPE 190 SX	M4	60	27.5	OE977PXU
OPE 210 X	M5	68	35	OE778PXL	OPE 210 SX	M5	68	35	OE978PXV

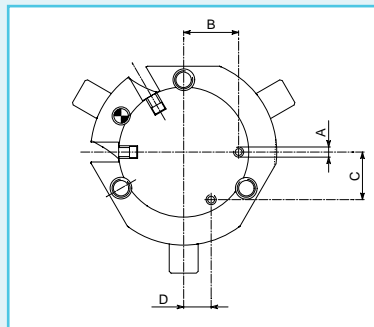

Sigla Code Bezeichnung Sigle	A	B	C	D	Codice Article code Artikelcode Code article	Sigla Code Bezeichnung Sigle	A	B	C	D	Codice Article code Artikelcode Code article
OPE 60-3 X	M3	20	17.3	10	OE870PXA	OPE 60-3 SX	M3	20	17.3	10	OE670PXL
OPE 65-3 X	M3	24	20.8	12	OE871PXB	OPE 65-3 SX	M3	24	20.8	12	OE671PXN
OPE 80-3 X	M3	24	20.8	12	OE872PXC	OPE 80-3 SX	M3	24	20.8	12	OE672PXN
OPE 90-3 X	M3	30	26	15	OE873PXD	OPE 90-3 SX	M3	30	26	15	OE673PXO
OPE 105-3 X	M3	32.5	28.1	16.25	OE874PXE	OPE 105-3 SX	M3	32.5	28.1	16.25	OE674PXP
OPE 110-3 X	M4	38	32.9	19	OE879PXF	OPE 110-3 SX	M4	38	32.9	19	OE679PXQ
OPE 125-3 X	M4	41	35.5	20.5	OE875PXG	OPE 125-3 SX	M4	41	35.5	20.5	OE675PXR
OPE 175-3 X	M4	46.5	40.3	23.25	OE876PXH	OPE 175-3 SX	M4	46.5	40.3	23.25	OE676PXS
OPE 205-3 X	M5	57.5	49.8	28.75	OE877PXI	OPE 205-3 SX	M5	57.5	49.8	28.75	OE677PXT

• Le dimensioni sono indicative e suscettibili di variazioni per migliori tecniche. Ci riserviamo di apportare modifiche senza preavviso • All dimensions are indicative and subject to variation for technical upgrading. We reserve the right to make alterations without prior notification • Die Maßangaben sind indikativ und können sich bei technischen Verbesserung ändern. Wir behalten uns vor, ohne vorherige Benachrichtigung Änderungen vorzunehmen • Les dimensions sont fournies à titre indicatif, elles peuvent subir des variations pour cause d'améliorations techniques. Nous nous réservons le droit d'apporter des modifications sans préavis.



- **NOTE**
- **Notes**
- **Anmerkungen**
- **Notes**

